Guide to the Measurement of Force

The Institute of Measurement and Control
87 Gower Street
London
WC1E 6AA

ISBN 0 904457 28 1

Published 1998

20.193e

KISTLER

NPL 
National Physical Laboratory



Guide to the Measurement of Force

COMMITTEE RESPONSIBLE FOR THIS GUIDE

This Guide to the Measurement of Force has been prepared by the National Physical Laboratory and the Institute of Measurement and Control, supported by the National Measurement System Policy Unit of the Department of Trade and Industry.

An independent panel of force specialists, as listed below, developed the structure and content of the Guide.

Andy Hunt, <i>Coordinator</i>	Andrew Hunt Consultants Ltd.
Anthony Cross	Nobel Systems Ltd.
Mike Crossman	UKAS
John Davis	Davis Decade Ltd.
Ural Erdem	Negretti Automation Ltd.
Allan Herbert	DERA Pyestock
Ray Jenkins	National Physical Laboratory
Andy Knott	National Physical Laboratory
Steve Maclean	Veccer
Leonard March	Kistler Instruments Ltd.
Dave Tame	Sheffield Testing Laboratories
Gary Thompson	Eagle Star Insurance Co. Ltd.
David Viney	Nobel Systems Ltd.
John Webb	Avery Berkel Ltd.
Gavin Wort	DERA Pyestock.

The panel would like to thank Colin Carter, Assistant Secretary of the Institute of Measurement and Control for his support in operating the panel meetings and Ken Chatters and Wilf Fry for their valuable comments on the document.

This guide refers to other publications that provide information or guidance. The editions listed are believed to be current at the time of publication, but reference should be made to the latest editions.

This Guide is subject to review by the responsible technical group of the Institute of Measurement and Control. The Institute welcomes all comments on the Guide and requests that these be addressed to the Institute.

Users of this Institute of Measurement and Control Guide shall be responsible for its correct application.

No part of this publication may be reproduced in any form without the prior permission in writing of the Institute of Measurement and Control.

Published by the Institute of Measurement and Control. Further copies are available from the Institute.

© Crown copyright 1998. Reproduced by permission of the Controller of HMSO. ISBN 0 904457 28 1.

FOREWORD

This Guide has been written to meet the need for a basic advisory document for users of force instrumentation. As in other fields of measurement, a consistent and harmonised approach is increasingly important, as is a common understanding of the terms used to define and describe force measurement. This Guide brings together information which exists already in the public domain but is in many cases difficult to obtain, poorly expressed, or widely misunderstood.

The Guide is intended to be practical; readily applicable; widely acceptable; accessible; and to contain objective criteria against which good practice can be judged. The advice given here is carefully selected to represent conventional good practice in force measurement, to be consistent with recognised standard specifications relevant to force, and to be free from commercial bias.

While this document provides a general introduction to force measurement it is not an in-depth scientific treatment of the subject. The further information sources section is provided as a starting point for those wishing to develop a more detailed understanding.

It is in the interest of many groups and individuals that information about good measurement practices should reach all those who can contribute and benefit. Accordingly, this document has been written in collaboration between the Institute of Measurement and Control, the National Physical Laboratory and an independent panel of experts involved in the supply, calibration and use of force measurement systems, and in consultation with a wide circle of users in the UK and further afield. The creation of the document was made possible by support from the National Measurement System Policy Unit of the Department of Trade and Industry, and by the voluntary effort of many of the individuals involved. All readers of this Guide owe a debt of gratitude to those who have contributed to its preparation.



C.R. Howard
President
The Institute of Measurement and Control

Guide to the Measurement of Force

CONTENTS

1	SCOPE	3
2	INTRODUCTION	3
3	CONCEPTS IN FORCE MEASUREMENT	4
3.1	The SI system of units	4
3.2	Force and other physical quantities	4
3.3	Measurement terminology	6
3.4	Force measurement systems	6
3.5	Characteristics of force measurement systems	7
4	INTRODUCTION TO METHODS OF FORCE MEASUREMENT	10
4.1	Overview	10
4.2	Strain gauge load cells	11
4.3	Piezoelectric crystal force transducers	15
4.4	Measuring force through pressure	17
4.5	Other types of force measurement system	17
5	APPLICATIONS	20
5.1	Range of applications	20
5.2	During development of a product	20
5.3	During the manufacturing process	21
5.4	Systems that measure or control force for safe operation	22
5.5	Process weighing	23
5.6	Requirements on uncertainty	23
6	CHOICE, DESIGN AND OPERATION OF SYSTEM	24
6.1	Choice of force measurement system	24
6.2	Design considerations	26
6.3	Operating the force measurement system	27
6.4	General Do's and Don'ts	28
6.5	Working with the supplier	29
7	CALIBRATION	31
7.1	Overview	31
7.2	Standards and traceability	31
7.3	Multi-axis and dynamic calibration	32
7.4	Options	32
7.5	Calibration procedures	33
8	QUALITY ASSURANCE OF FORCE MEASUREMENTS	37
8.1	Measurement accreditation	37
8.2	Competence in force measurement	37
9	WORKED EXAMPLES	38
9.1	Example: Measurement of web tension	38
9.2	Example: Force measurement on a mechanically-driven power press	40
9.3	Example: Spring force test on a personal computer mouse	41
9.4	Example: Force measurement in bio-mechanics	42
10	FURTHER INFORMATION SOURCES	43
10.1	Bibliography	43
10.2	Useful addresses	44
11	INDEX	45

FIGURES

Figure 1. Typical output characteristics of a force measurement system.....	7
Figure 2. Creep curve of a typical force transducer.....	8
Figure 3. Basic diagram of an elastic transducer element.....	10
Figure 4. Typical strain elements and their usual rated capacities.....	12
Figure 5. Typical metal foil strain gauges.....	12
Figure 6. Basic arrangement of four strain gauges.....	14
Figure 7. Arrangement of strain gauges in a typical commercial load cell.....	14
Figure 8. A range of industrial load cells.....	15
Figure 9. Industrial piezoelectric load washers.....	16
Figure 10. Mounting of a load washer.....	16
Figure 11. Multi-component crystal force sensor.....	16
Figure 12. An example of a hydraulic load cell.....	17
Figure 13. A shear pin force transducer.....	21
Figure 14. Vessel supported by four load cells.....	23
Figure 15. Typical instrumentation combinations.....	25
Figure 16. Front page of a calibration certificate.....	35
Figure 17. An example calibration certificate.....	36
Figure 18. Forces on the roller.....	38
Figure 19. Vector diagram of forces.....	38
Figure 20. Alignable force transducers.....	38
Figure 21. Force transducers in solution 2.....	39
Figure 22. Sensor locations on a C-frame press.....	40
Figure 23. Blank and draw tool.....	41
Figure 24. Load curve examples.....	41
Figure 25. Response curve from mouse 'click' testing.....	41
Figure 26. A transparent multi-component force plate.....	42
Figure 27. Example of human gait analysis.....	42

TABLES

Table 1. SI notation for large and small numbers.....	4
Table 2. Approximate conversion factors to some non-SI force units.....	5
Table 3. Guide to force transducer types and characteristics.....	11
Table 4. Instrumentation associated with common transducer types.....	26
Table 5. Check list of potential requirements for a force measurement system.....	30
Table 6. Types of force standard machine.....	32

Guide to the Measurement of Force

1 SCOPE

This guide aims to help anyone wishing to measure force in any industrial or laboratory environment. It is essentially a guide for the user of the measurement and should help him or her to understand the range of measurement techniques available, how to characterise the requirements of his or her particular problem, and how to communicate those needs to manufacturers and suppliers of force measurement equipment. It also aims to give an understanding of the needs for, and methods of, calibrating, operating and maintaining force measurement systems.

The techniques described cover the majority of problems encountered in force measurement, but where the guide cannot go into sufficient detail, the reader is referred to further published documents.

The range of forces covered is from approximately 10^{-3} to 10^9 newtons, and those forces may be static or dynamic and single or multi-axis.

The guide is to the measurement of force, including the use of load cells, but force measurement is frequently an integral part of the measurement of weight, torque, impact and acceleration. The guide does not enter into the details of the metrological requirements and problems of those applications, but is of direct use in the way the force measurement system is designed and applied to those needs.

2 INTRODUCTION

The forces acting within and between parts of a mechanism are fundamental to the safety, assembly and use of any piece of equipment, whether that equipment be freely acting or an integral part of a process. The measurement of those forces is vital to understanding and monitoring the activity which the machine is designed to undertake.

Force measurement is needed in many industries, and though the precision required may vary from a few per cent to a few parts per million, the general approaches to good practice are common if the user is to achieve a reliable measurement of the precision that he or she requires. Good practice leads to good value for money, and contributes to the long-term reliability of the device. The time taken to understand how to make good force measurement should be regarded as an investment which will pay off quite quickly. A number of examples are used in the text to help in understanding the concepts and techniques described, but these should not be regarded as limiting. There are many more industries and applications which need force measurement than can be explicitly mentioned here.

To make reliable and accurate measurements of force, it is necessary to use appropriate measurement techniques, properly calibrated, in a sound manner. This guide is written such that a relatively inexperienced user may expect to follow through in a sequential fashion and learn these 'tools of the trade'. For the benefit of more experienced practitioners, the guide has an extensive index to help in its use as an aide-memoire. Certain words and phrases are used very specifically in measurement, which is known as the science of *metrology*. In this guide these terms are clearly defined when they are first met in the text (where they are in bold italic typeface – like '*metrology*,') and a reference to the definition is given in the index. Many of the general definitions are gathered together in Section 3 and on first reading of the document it may be easier to skip that Section and to check the meaning of any unknown words through the index as necessary.

This guide is based entirely in the SI system of units, and the equations here should only be used with that coherent system of units. Although other units may still be encountered, the use of the newton is consistent with the international community, and eliminates much confusion and possible sources of error.

3 CONCEPTS IN FORCE MEASUREMENT

3.1 The SI system of units

It is conventional practice to express any measurable physical quantity as a numerical value associated with a **unit** of measure. The international system of units (known as *SI*) is coherent, meaning that there are no conversion factors in mathematical expressions linking a base unit with a derived unit, and it is widely accepted as the standard for national and international trade, science and engineering. In the SI system there are seven base units of which the three of main interest to us here are:

- the metre, unit of length, symbol m,
- the kilogram, unit of mass, symbol kg,
- and the second, unit of time, symbol s.

Derived units are those units, such as force, which can be derived by mathematical combination of base units.

To avoid the regular use of very long numbers, SI encourages the use of multiples of 1 000, (expressed as 10^3 in *scientific notation*) for large numbers, and multiples of 0.001 (or 10^{-3}) for small numbers. Each of these multiplying factors has a specific symbol, some of which are shown in Table 1. In this way, for example, a force of 75 400 000 N (seventy five million four hundred thousand newtons), can be written much more succinctly as 75.4 MN (seventy five point four mega-newtons), and a force of 0.057 N can be written as 57 mN (fifty seven milli-newtons). There does remain one anomaly in the system because of the use of the kilogram as the base unit of mass rather than the gram. This anomaly means that in the measurement of mass the prefixes above 10^3 (kilo) do not apply, and instead the term tonne is used for 1 000 kg.

Table 1. SI notation for large and small numbers

Multiplying factor	SI prefix	Scientific notation
1 000 000 000 000	Tera (T)	10^{12}
1 000 000 000	Giga (G)	10^9
1 000 000	Mega (M)	10^6
1 000	kilo (k)	10^3
0.001	milli (m)	10^{-3}
0.000 001	micro (μ)	10^{-6}
0.000 000 001	nano (n)	10^{-9}
0.000 000 000 001	pico (p)	10^{-12}

3.2 Force and other physical quantities

3.2.1 Mass

Mass is a measure of the amount of material in an object, being directly related to the number and type of atoms present in the object. Mass does not change with position, movement or alteration of the body's shape unless material is added or removed. The unit of mass in the SI system is the kilogram (kg) which is defined to be equal to the mass of the international prototype mass held in France.

The measurement of mass is a subject of significant importance to trade, and is treated in a sister document to this one, 'Guide to the Measurement of Mass and Weight' [26].

3.2.2 Force

Force is a measure of the interaction between bodies. Force takes a number of forms including short-range atomic forces, electromagnetic, and gravitational forces. Force is a vector quantity, with both direction and magnitude. If the forces acting on a body in equilibrium are summed around the periphery of the body then they add to zero. If there is any resultant force acting then the body is not in equilibrium and it will accelerate such that the rate of change of the body's momentum (velocity times mass) is equal and opposite to the force. If the body is held stationary in some way, then there will be a **reaction** acting on the body from the support structure that is equal in magnitude and opposite in direction to the force imposed. Although the definition of force units (as given below) is based on acceleration of a free body, most force measurements are made on bodies in equilibrium, and are therefore measures of forces within a structure. Conceptually a structure can be 'cut' across any section and the forces acting within the body at that section are those which would act at the free surfaces if such a cut were made. This property is the basis of most force measurements – a physical support or link in a structure is replaced with a device that measures the forces acting at that point.

As with any vector quantity, the force and reaction may be projected onto three orthogonal axes, and the equilibrium may be considered independently parallel to each of those axes. Frequently a force measurement system will react properly only to forces along its **principal axis**, and if this should not coincide exactly with the direction of the total applied force to be measured then an erroneous result will be generated.

The SI unit of force is the **newton** (N); defined as the unit of force which would give to a mass of one kilogram an acceleration of 1 metre per second, per second. It is not convenient, in practice, to produce an acceleration of 1 metre per second, per second acting on a mass of one kilogram in order to realise a standard of force of 1 newton. Instead the practical realisation of the unit of force makes use of known masses, which when subjected to the effect of local gravitational force, exert a known force on an earth located support. The mechanical structure to handle and control such masses is known as a deadweight machine.

Historically there have been a variety of units of force, and some approximate conversion factors to older units are given in Table 2.

Table 2. Approximate conversion factors to some non-SI force units

Unit	Symbol	Is equivalent to
pound-force	lbf	4.448 N
ton-force	tonf	9.964 kN
kilogram-force (or kilopond)	kgf (kp)	9.807 N

3.2.3 Weight

In the trading of goods, **weight** is taken to mean the same as mass, and is measured in kg. Scientifically however, it is normal to state that the weight of a body is the gravitational force acting on it and hence it should be measured in Newtons, and that this force depends on the local acceleration due to gravity. To add to the confusion, 'a weight' is a calibrated mass normally made from a dense metal. Because of the confusion surrounding the term, it will not be used in this document except in the sense of referring to weighing as a process for determining the mass of an object.

3.2.4 Load

Load is a term frequently used in engineering to mean the force exerted on a surface or body. It is a word that will not be generally used here, except in the common usage of 'load cell' which is a well-known term for various types of force measurement transducer, and in the term **overload** for a force exceeding the rated capacity of a force measurement system.

3.3 Measurement terminology

The definitions used in this guide follow British [5] and International [18] standards in metrology. In passing it is worth noting that even the word *standard* has two meanings. The first meaning is a *material measure* (often known as an *artefact*) such as the standard kilogram which is a particular carefully made and preserved metallic cylinder. The second meaning is a *documentary standard* such as BS5233 that is a textual document representing a national or international agreement on meanings or methods.

For the measurement of a force device to be of any use, the *accuracy* of that measurement must be known. However as the term accuracy can only be used in a qualitative manner, a quantitative term is required, this being *uncertainty*. The uncertainty of measurement is an estimate that characterises the range of values within which the true value is believed to lie. There are three documents in the bibliography covering this subject in detail, the ISO document [17], the BSI publication which is directly equivalent [16], and a very helpful but less comprehensive guide from NAMAS [31]. Note that uncertainties should be quoted at a *level of confidence* (for example 95%) for them to be meaningful. A 95% confidence level implies that the true value of the force has a 95% chance of lying within the stated range. Uncertainties are normally expressed as per-cent of full-scale output, as they are within this document.

Performance criteria for a force measurement system are described by the manufacturer in terms of a *specification* which gives limits within which the behaviour of the instrument can be expected to fall. For instance if an instrument is specified to have an uncertainty of $\pm 0.3\%$ of full-scale output, then the user can reasonably hope that if the instrument is used correctly, the value of force it indicates will be correct, give or take 0.3% of the full-scale output. (Bear in mind that if a device of rated output 5 kN is used to measure a force of 500 N, then the uncertainty for the same specification would be 3% of reading rather than 0.3%.) However, this performance is generally given for a production series, and cannot be relied upon for a specific device unless verified by calibration. A specification is not the same as a calibration, and is no substitute for one.

Calibration is the process of comparing a measuring instrument against an authoritative reference for the same type of measurement and is extensively discussed in Section 7.

3.4 Force measurement systems

A *force measurement system* is made up of a transducer and associated instrumentation. The transducer is subjected to the force to be measured, and some resultant change in the element is measured by the associated instrumentation. The instrumentation may power the transducer in some way and also may process the output from the transducer before it is shown on an indicator to be read by the user. Strictly a *transducer* is a device that receives a physical stimulus and changes it into another measurable physical quantity through a known relationship. In practice a *force transducer* is a chain of several transducers, for example the force may act upon a metal cylinder which is compressed by the force, the change in size alters the electrical resistance of a strain gauge bonded to the surface of the cylinder, and the instrumentation measures this change in resistance. In this guide the term force transducer will be used loosely to describe the part of the force measurement system which converts the applied force into an output which is measured by some associated instrumentation.

For many types of force measurement system the term *load cell* is in common usage in place of force transducer. Also, the term *device* is from time to time used in place of transducer within the text of this guide to avoid distracting repetition of the word transducer. For the same reasons, the term *measuring instrument* will occasionally be used with the same meaning as force measurement system.

As will be seen in the following sections, the *instrumentation* may be as simple as a dial gauge or as complex as a computer with associated analogue to digital converters and excitation circuitry. The *indicated value* is the *output* of the force measurement system, which may be in units of force or other units such as volts. If the indicated value is not in units of force, then the user may need to perform a calculation based on a calibration to obtain the *calculated value*.

A force transducer is frequently built in as an integral part of a structure or machine, and many force calibration devices (see Section 7) are themselves machines. It is often therefore difficult to consider the force measurement system separately from the application and this has many effects on the procedures for design, calibration and operation of the system (see Sections 6 and 7).

3.5 Characteristics of force measurement systems

In the following sections various force measurement systems are mentioned with many different physical principles involved in their operation. The performance of these systems, however, can be described by a number of common characteristics and the behaviour of the system or the transducer may be expressed graphically by plotting the indicated output value against the applied force to generate that value (known as a *response curve*). Figure 1 shows an idealised response curve of a force measurement system to a force which is increased from zero to the rated capacity of the force measurement system and then back again to zero. The *rated capacity* is the maximum force that a force transducer is designed to measure. The example in the figure is only one of several ways to define these terms, in this case based on the best straight line through zero, for more detail see [29]. It should also be emphasised that all the terms used in this section may be applied independently to the transducer, the force measurement system as a whole, or some part of the system. The user should establish for any given application the way in which the terms are being used.

The deviation of the response curve from a straight line is magnified in the figure for the purposes of clarity. A commonly used method of characterising the performance of this system is based on the fitting of a best-fit least-squares line, passing through zero, to the increasing load readings and stating the errors with respect to this line. Deviation from this best fit line is referred to as *non-linearity* and generally the largest deviation is given in the specifications of a system. The difference of readings between the increasing and decreasing

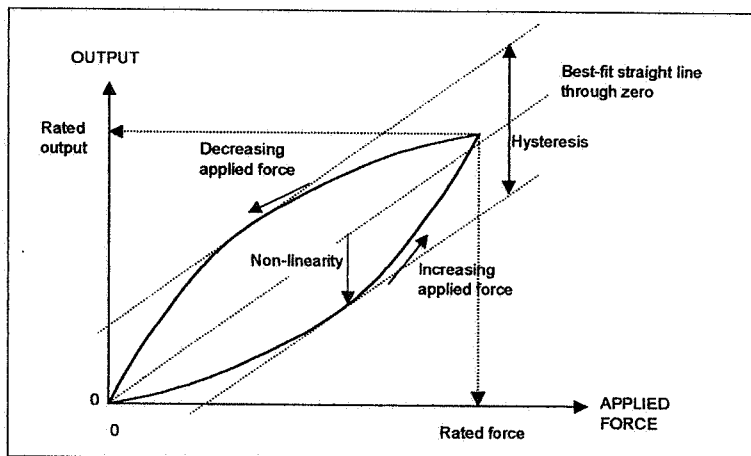

forces at any given force is defined as the *hysteresis*. The largest value of hysteresis is usually at the mid-range of the system. Sometimes it may be useful to combine the non-linearity and the hysteresis in a single figure. This is usually done by drawing two lines parallel to the best-fit line such that these lines enclose the increasing and decreasing force curves. The difference of output between the lines is halved and stated as *±combined error*.

Figure 1. Typical output characteristics of a force measurement system

Any difference between the indicated value of force and the true value is known as an *error of measurement*, and the errors noted above may be expressed as percentage of actual force applied or percentage of full-scale output. *Full-scale output (fso)*, also known as *span* or *rated output*, is the output at rated capacity minus the output at zero applied force. *Sensitivity* is defined as the full-scale output divided by the rated capacity of a given load cell.

The ability of a force measurement system to measure force consistently is covered by the concept of repeatability. *Repeatability* is defined broadly as the measure of agreement between the results of successive measurements of the differences of output of a force measurement system for repeated applications of a given force in the same direction and within the range of calibration forces applied. The tests should be made by the same observer, with the same measuring equipment, on the same occasion, without mechanical or electrical

disturbance, and calibration conditions such as temperature, alignment of loading and the timing of readings held constant as far as possible. Although many manufacturers quote a value for repeatability as a basic characteristic of a transducer, it can be seen from the definition that repeatability should not be considered as such. The value obtained for a given force transducer in a given force standard machine will depend not only on the true characteristics of the device such as its creep and sensitivity to bending moments, but also on temperature gradients, resolution and repeatability of the electrical measuring equipment and the degree to which the conditions of the tests are held constant, all of which are characteristics of the test procedure. The value of repeatability obtained is important as it limits the accuracy to which the characteristics of the force transducer can be measured.

In contrast to repeatability, **reproducibility** is defined as the closeness of the agreement between the results of measurements of the same force carried out under changed conditions of measurement. Note that a valid statement of reproducibility requires specification of the conditions changed and may include changes in the principle of measurement, method of measurement, observer, measuring instrument, reference standard, location, conditions of use and time.

A force measurement system will take some time to adjust fully to a change in force applied, and **creep** of a force transducer is usually defined as the change of output with time following a step increase in force from one value to another. Most manufacturers specify the creep as the maximum change of output over a specified time after increasing the force from zero to the rated force. Figure 2 shows an example of a creep curve where the transducer exhibits a change in output from F_1 to F_2 over a period of time from t_1 to t_2 after a step change between 0 and t_1 . In figures this might be say 0.03% of rated output over 30 minutes. **Creep recovery** is the change of output following a step decrease in the force applied to the force transducer, usually from the rated force to zero.

For both creep and creep recovery, the results will depend on how long the force applied has been at zero or the rated value respectively before the change of force is made.

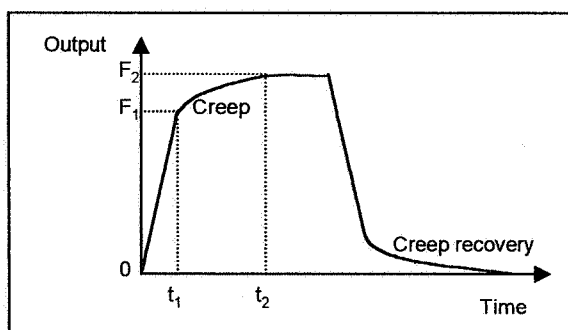

Figure 2. Creep curve of a typical force transducer

The frequency response of a force transducer is affected by the nature of the mechanical structure, both within the transducer and of its mounting. A force transducer on a rigid foundation will have a **natural frequency** of oscillation and large dynamic errors occur when the frequency of the vibration approaches the natural frequency of oscillations of the system.

The effect of temperature changes is felt on both the zero and rated output of the force measurement system. The **temperature coefficient** of the output at zero force and the temperature coefficient of the sensitivity are measures of this effect for a given system. A force measurement system may need to be kept at constant temperature, or set up well in advance to settle in to the ambient conditions if high accuracy measurements are required. In some cases the temperature gradients within the measurement installation create a problem even when the average temperature is stable.

Other **influence quantities** such as humidity, pressure, electrical power changes or radio-frequency interference may have analogous effects to those of temperature and may be considered in a similar manner.

In general, a force transducer has two interfaces through which a force is applied. These may be the upper and lower **loading surfaces** of a compression force transducer or the upper and lower screw threads of a tension device. In some load cells, one or both interfaces are part of the elastic element to which the strain gauges are bonded; in other transducers the interfaces may be remote from the elastic element. At each interface, there will be a force distribution which will depend on the end loading conditions. A change in these **loading conditions**, therefore, may cause a change in the force distribution resulting in a change of the sensitivity of

the transducer, even though the resultant force at the interface remains unchanged. The European standard [11] concerned with the calibration of proving devices for the verification of materials testing machines recognises the importance of end loading conditions by requiring compression proving devices to pass a bearing pad test. In this test, a device is loaded through a flat steel pad and then through each of two steel pads that are conically convex and concave respectively by 1 part in 1 000 of the radius. Depending on the design of the transducer, the change of sensitivity caused by a change of end loading conditions can be quite large; some precision compression load cells with low creep, hysteresis and temperature coefficients can show differences of sensitivity in the bearing pad test of 0.3%, others less than 0.05%.

True *axial alignment* of the applied force along the transducer's principal axis, and the loading conditions across that surface are major factors in the design of a reliable and accurate installation of a force measurement system. Force transducers used to measure a single force component are designed to be insensitive to the orthogonal force components and corresponding moments, provided these are within specified limits, but although the error due to small misalignments may be calibrated statically, the alignment of force relative to the transducer axis may vary through the load cycle of a typical application giving potentially large and unquantifiable errors of measurement. Users of force measurement systems should adhere to manufacturer's recommendations for alignment when installing force transducers.

The *long-term stability* of the sensitivity of force measurement systems is clearly important if they are to be used to compare the magnitude of forces at different times, perhaps months or years apart. The long-term stability will be determined by several factors including the stability of the force transducer's many components, the protection of the strain gauges or other parts against humidity, and the conditions under which the system is stored, transported and used.

A *dynamic force* is one which varies with time. To measure any instantaneous value requires that the frequency response of the force measurement system must be sufficient to be able to follow the changing force. A definition of *frequency response* is the highest sinusoidal frequency of applied force which the system can measure to a specified accuracy. Also if a transducer is to be used with fluctuating forces applied then its fatigue life should be considered. *Fatigue life* may be defined as the number of total full cycles of applied force which may be applied before the measurement uncertainty will be altered beyond specified limits.

While manufacturers of force measurement systems tend to use their own set of descriptions of the uncertainties associated with their system, the factors contributing to uncertainty in force measurement are largely covered by the description above. The list cannot be exhaustive, but is designed to alert the potential buyer and user of a system that he or she must understand the way the manufacturer uses the terminology and then establish the magnitude of those errors for his or her application.

4 INTRODUCTION TO METHODS OF FORCE MEASUREMENT

4.1 Overview

There are many types of force transducer, and these may be used with instrumentation of varying complexity. In designing or specifying a force measurement system for an application, it is useful to understand the basic operation of the transducer to be used. This chapter describes transducer and instrumentation types in approximately the order of their commercial importance starting with the types most widely used. A summary of the characteristics of the various devices described in this document is given in Table 3. The figures in the table represent typical values, transducers and systems will often operate outside these ranges but with increased uncertainty.

Many force transducers employ some form of elastic load-bearing element or combination of elements. Application of force to the elastic element causes it to deflect and this deflection is then sensed by a

secondary transducer which converts it into an output. The output may be in the form of electrical signal as in strain gauge and LVDT type load cells or mechanical indications as in proving rings and spring balances. Such transducers are known generically as elastic devices, and form the bulk of all commonly used force transducers. There are a number of different elastic transducer elements but generally they consist of circular rings, cylinders or beams.

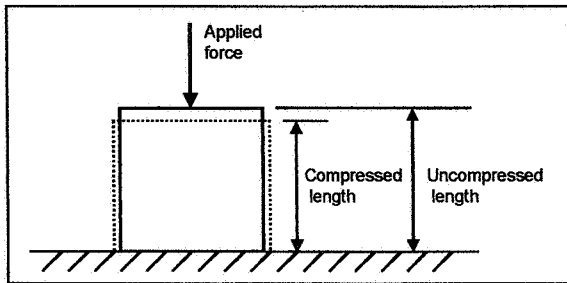

Figure 3. Basic diagram of an elastic transducer element

The fundamental nature of elastic devices is illustrated in Figure 3. The elastic element in this case is a circular cylinder made of a metal such as steel. The force is applied to the end of the cylinder and the deformation is measured as the difference between the uncompressed and compressed length. The cylinder also expands outwards as it is compressed, the ratio of outward expansion to longitudinal compression being determined by the nature of the material (through Poisson's ratio). The force may also be applied such that the device is in tension, and in that case the distortion is simply reversed.

All elastic devices share this common basis, but the method of measuring the distortion of the elastic element varies considerably. The most frequent method is to make measurements of the longitudinal and lateral strain, and when this is undertaken by electrical resistance strain gauges such a transducer is known as a strain gauge load cell. Strain gauge load cells are the most common commercially available type of force transducer and are described in Section 4.2. Other types of elastic transducer which are less commonly used are described in Section 4.5.

Another commonly used type of force measurement transducer is based on the piezoelectric phenomenon exhibited by certain crystalline materials where an electric charge is generated on the crystal surface, the amount of charge being proportional to the rate of change of applied force. Such devices are now widely available and are described in Section 4.3.

Many other physical relationships may be used in force measurement transducers. Pressure-based systems are covered in Section 4.4, while a range of other devices is described in Section 4.5.

Table 3. Guide to force transducer types and characteristics

Device type	Typical range of rated capacities	Typical total uncertainty % fso	Temperature sensitivity and operating range % fso per °C
<i>Strain gauge load cells:</i>			
Semiconductor gauges	1 N to 10 kN	±0.2% to ±1%	0.2% to 0.5% (-40°C to +80°C)
Thin film gauges	0.1 N to 100 N	±0.02% to ±1%	0.02% (-40°C to +80°C)
Foil gauges	5 N to 50 MN	±0.02% to ±1%	0.0015% (-40°C to +80°C)
<i>Piezoelectric crystal</i>	1.5 mN to 120 MN	±0.3% to ±1%	0.02% (-190°C to +200°C)
<i>Hydraulic</i>	500 N to 5 MN	±0.25% to ±5%	0.02% to 0.1% (5°C to 40°C)
<i>Pneumatic</i>	10 N to 500 kN	±0.1% to ±2%	0.02% to 0.1% (5°C to 40°C)
<i>LVDT, capacitive, tuning-fork, vibrating wire</i>	10 mN to 1 MN	±0.02% to ±2%	0.02% to 0.05% (-40°C to +80°C)
<i>Magneto-elastic</i>	2 kN to 50 MN	±0.5% to ±2%	0.03% to 0.05% (-40°C to +80°C)
<i>Gyroscopic**</i>	50 N to 250 N	±0.001%	0.0001% (-10°C to +40°C)
<i>Force balance**</i>	0.25 N to 20 N	1 part in 10 ⁶	0.0001% (-10°C to +40°C)

4.2 Strain gauge load cells

The most common type of force transducer, and one which is a clear example of an elastic device, is the *strain gauge load cell*. Each cell is based on an elastic element to which a number of electrical resistance strain gauges are bonded. The geometric shape and modulus of elasticity of the element determine the magnitude of the strain field produced by the action of the force. Each strain gauge responds to the local strain at its location, and the measurement of force is determined from the integration of these individual measurements of strain.

The rated capacities of strain gauge load cells range from 5 N to more than 50 MN and they have become the most widespread of all force measurement systems. They can be used with high resolution digital indicators as force transfer standards. The specification, calibration and testing of strain gauge load cells is covered in detail in [29], to which document the user is referred if the present guide does not have sufficient detail for his or her application.

4.2.1 The elastic element

The shape of the *elastic element* used in load cells depends on a number of factors including the range of force to be measured, dimensional limits, final performance and production costs.

Figure 4 shows a selection of different elastic elements and gives their typical rated capacities. Each element is designed to measure the forces acting along its principal axis, and not to be affected by other forces such as side loads. The arrows in the figure indicate the principal axis of each element.

** Many sorts of displacement transducer may be used with the gyroscopic load cell and the force balance. The exact performance limits will depend on the specific type used.

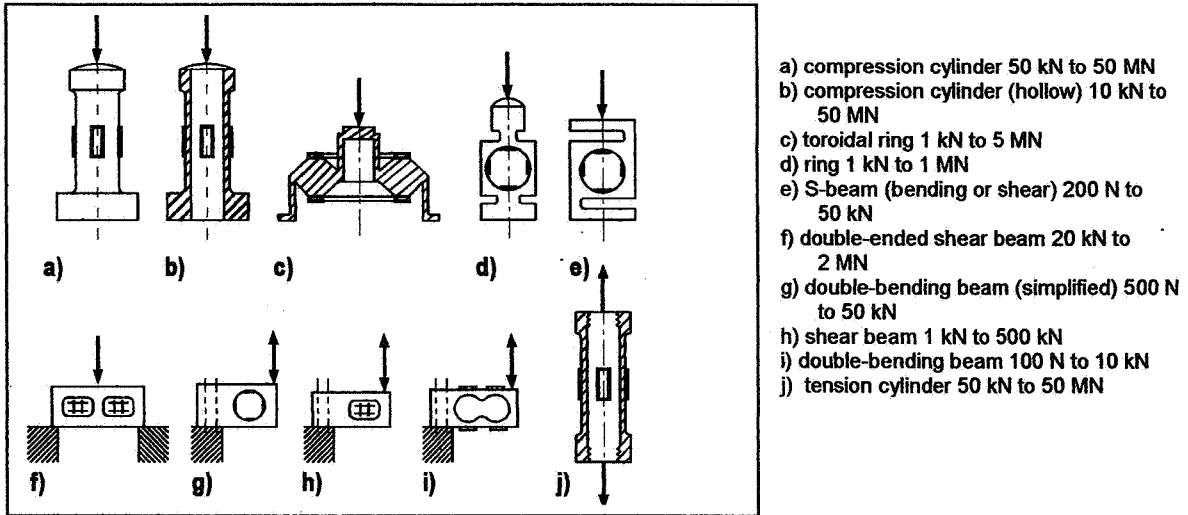

Figure 4. Typical strain elements and their usual rated capacities

The material used for the elastic element is usually tool steel, stainless steel, aluminium or beryllium copper, the aim being a material which exhibits a linear relationship between the stress (force applied) and strain (output) with low hysteresis and low creep in the working range. There also has to be high level of repeatability between force cycles to ensure that the load cell is a reliable measuring device. To achieve these characteristics it is usual to subject the material to a special heat treatment. This may include a sub-zero heat treatment cycle to achieve maximum stability.

4.2.2 The electrical resistance strain gauge

In electrical terms, all *electrical resistance strain gauges* may be considered as a length of conducting material, like a wire. When a length of wire is subjected to a tension within its elastic limit, its length increases with corresponding decrease in its diameter and change of its electrical resistance. If the conducting material is bonded to an elastic element under strain then the change in resistance may be measured, and used to calculate the force from the calibration of the device.

The most common materials used for the manufacture of strain gauges are copper-nickel, nickel-chromium, nickel-chromium-molybdenum and platinum-tungsten alloys and these are generally referred to by their trade names. There are a variety of resistance strain gauges available for various applications, some of which are described below. Each strain gauge is designed to measure the strain along a clearly defined axis so that it can be properly aligned with the strain field.

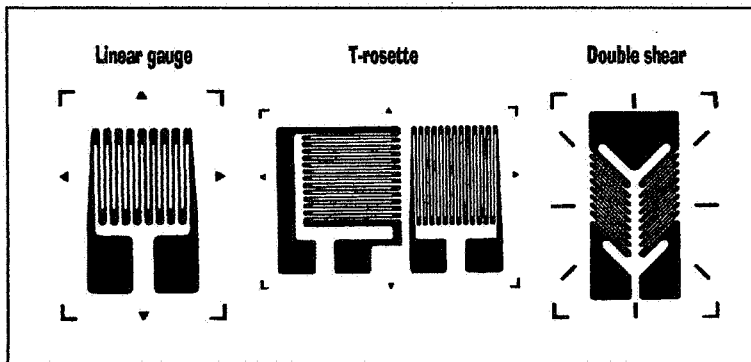

Figure 5. Typical metal foil strain gauges

The *foil strain gauge* is the most widely used type and several examples are shown in Figure 5. It has significant advantages over all other types of strain gauge and is employed in the majority of precision load cells.

The foil strain gauge consists of a metal foil pattern mounted on an insulating backing or carrier, constructed by bonding a sheet of thin rolled metal foil, 2-5 μm thick, on a backing sheet of 10-30 μm thick. The measuring grid pattern including the terminal tabs is produced by photo-etching. The production techniques used are similar to those used in the integrated circuit manufacturing industry and lend themselves to automation and thus low unit cost. Typical backing materials are epoxy, polyimide and glass-reinforced epoxy phenolic resin. The backing provides electrical insulation between the foil and the elastic element, facilitates handling and presents a readily bondable surface. Sometimes the gauge is manufactured backed with an adhesive layer, reducing the amount of handling needed and time consumed. The epoxy or epoxy-derived backing material is difficult to handle due to its brittle nature, but it is preferred for use in high-precision load cells because of its superior performance especially in creep and low level of moisture absorption compared to polyimide type plastic. A large variety of foil gauges are now commercially available to the transducer designer and general user.

Semiconductor strain gauges are manufactured from strips of semi-conducting silicon in either the 'n' or 'p' form. The output from a semiconductor gauge is very high compared to a wire or foil gauge. The *gauge factor* is a measure of the output for a given strain, and is typically 100-150 for a semiconductor and 2-4 for wire and foil. The output from semiconductor gauges is non-linear with strain, but they exhibit essentially no creep or hysteresis and have an extremely long fatigue life. High temperature sensitivity of the gauges means that careful matching of the gauges is required on any given load cell, and they are usually computer matched into sets on manufacture, but a high level of temperature compensation may still be required on the completed transducer. This type of gauge is widely used on 'small' transducers such as force transducers, accelerometers and pressure sensors whose sensing element may be micro-machined out of a single piece of silicon.

Thin-film strain gauges are produced by sputtering or evaporating thin films of metals or alloys onto the elastic element. The manufacture of a thin film strain gauge system will go through several stages of evaporation and sputtering and may have up to eight layers of material. There are a number of thin-film strain gauge force transducers available covering a range of 0.1 N to 100 N in the form of a single- or double-bending beam configuration. These devices are highly cost effective when produced in large quantities due to the manufacturing techniques involved. This makes them ideally suited for use in large-volume products such as shop scales and pressure transducers.

The *wire strain gauge* was the original type of resistance strain gauge, though now widely replaced by cheaper foil or thin film types. However the wire strain gauge is still used extensively for high temperature transducers and stress analysis, and is available made from a wide range of materials. The wire is typically 20-30 μm in diameter and may be bonded to the substrate using ceramic materials. It is less commonly used in the 'free' form where the wire is looped around insulated pins which are mounted on the elastic member.

The nominal resistance of the strain gauge varies with the type and application. Wire gauges have resistances in the range of 60 Ω to 350 Ω , foil and semiconductor gauges from 120 Ω to 5 k Ω and thin film types around 10 k Ω . Selection criteria may include size, self-heating and power requirements. If several load cells are to be connected together then matched resistance may be important.

4.2.3 Instrumentation used for strain gauge devices

The strain gauge bonded to the elastic element is a secondary transducer converting the strain produced by the force applied to the element into resistance change. To maximise the response of the load cell it is normal to connect one or more strain gauges aligned to respond to the longitudinal strain and another set aligned with the transverse strain. When connected electrically as a *wheatstone bridge configuration*, this has the added advantage of minimising the effects of environmental changes such as temperature which act equally on all the gauges. The resistance change is detected by measuring the differential voltage across the bridge (see Figure 6).

A wheatstone bridge is normally formed by four strain gauges, although it is not uncommon to use two strain gauges for a 'half bridge', or more than four on elastic elements of complex shape. In the latter case half the

total number of strain gauges are subjected to compressive strains and the other half to tensile strains. The voltage output from the bridge when excited by an input voltage is linearly related to the resistance change of the strain gauges and is therefore a function of the force applied to the element. It can be shown that the output voltage is the mathematical product of the strain and the excitation voltage. The rated output of a load cell is normally standardised to a nominal level, usually 2 mV/V (2 millivolts output per volt applied) but this can range from 1 mV/V to 4 mV/V.

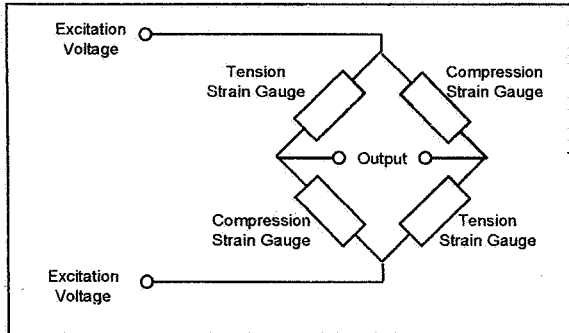

Figure 6. Basic arrangement of four strain gauges

The circuit diagram for a typical commercial load cell is given in Figure 7 showing the several correction and compensation components needed to realise the full capability of the strain gauge load cell.

A *shunt resistor* may be needed to perform a shunt calibration and this is often fitted in the signal conditioning unit to be switched across one arm of the bridge when required. Typical shunt calibration resistor values used for a 350 Ω bridge are 40 kΩ and 80 kΩ which equate to approximately 90% and 45% of full load on a 2 mV/V transducer.

A load cell is part of a measurement chain and it requires an excitation voltage to be supplied and amplification and conditioning of the output signal before it can be meaningfully displayed or used in a control system. Normally a DC system excites the load cell with a direct current (DC) voltage and amplifies the output through an instrumentation amplifier. This chain features wide frequency bandwidth, high stability and relatively low cost.

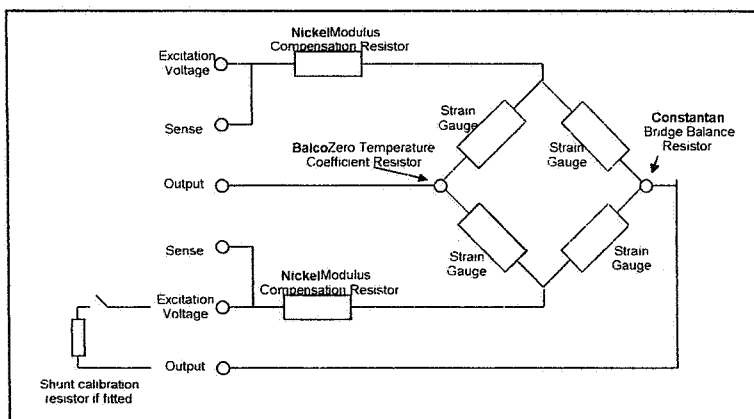

Figure 7. Arrangement of strain gauges in a typical commercial load cell

An alternative to DC excitation is the AC system, which excites the load cell with an AC signal sine wave, square wave or other periodically varying input. The output is processed through an AC amplifier, a synchronous demodulator, filter and DC amplifier. A high-level DC signal is obtained suitable for direct analogue display or for conversion to a digital display with the use of an analogue-to-digital converter (ADC). Such a system has a higher immunity to thermal effects in the instrumentation and thermo-electric effects in the transducer, high noise rejection, good zero force output stability and ease of achieving isolation between

In industrial applications, the distance between the load cell and the measuring instrument may be considerable, possibly hundreds of metres. The voltage drop along the connecting cable and its dependence upon temperature can contribute to the system error. This additional error can be remedied by the use of the *six-wire connection technique* shown in Figure 7. The voltage is sensed at the load cell and maintained at a constant pre-set level.

the signal output and the load cell. However, in view of the relatively complex measuring chain, these systems tend to be costly.

A strain gauge load cell has two distinct temperature coefficients (TC), one on zero load output and one on full-scale output. The former is caused by the effect of temperature on the strain gauge resistance, the mismatch between the expansion coefficient of the gauge and the spring element to which it is bonded, and the out-of-balance condition in the bridge wiring. The effect on full-scale output is mainly caused by the temperature dependence of the spring element material modulus of elasticity.

4.2.4 Housing

It is usually necessary to protect the elastic element, its strain gauges and associated electronic components since many load cells are exposed to harsh industrial environments. The way the load cell is housed depends on its intended application and there are a wide range of shapes and sizes including cylinders, rectangular and

circular beams, and tension devices like turnbuckles. The housing must allow for suitable fixings such as bolts or cradles and is critical in determining the correct transfer of the force to the elastic element. The housing used for this purpose also fulfils other functions such as limiting the side forces on the element and protecting the various electrical components. Various types of load cells are shown in Figure 8 and others will be illustrated later in the document associated with their applications.

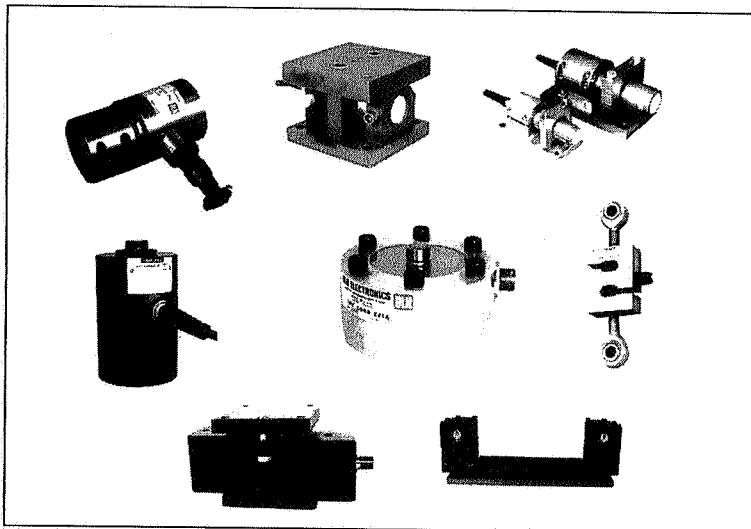

Figure 8. A range of industrial load cells

4.3 Piezoelectric crystal force transducers

When a force is exerted on certain crystalline materials, electric charges are formed on the crystal surface in proportion to the rate of change of that force. To make use of the device, a *charge amplifier* is required to integrate the electric charges to give a signal that is proportional to the applied force and big enough to measure. The first transducers to apply the piezoelectric effect for measurement used naturally grown quartz but today mostly artificial quartz is used. Because of this these devices are often known as *quartz force transducers*, though here more the general term *piezoelectric crystal* will be used.

These piezoelectric crystal sensors are different from most other sensing techniques in that they are active sensing elements. No power supply is needed and the deformation to generate a signal is very small which has the advantage of a high frequency response of the measuring system without introducing geometric changes to the force measuring path.

When packaged as a load washer (see Figure 9) and compressed under a force of 10 kN a typical piezoelectric transducer deflects only 0.001 mm. The high frequency response (up to 100 kHz) enabled by this stiffness and the other inherent qualities of the piezoelectric effect makes piezoelectric crystal sensors very suitable for dynamic measurements.

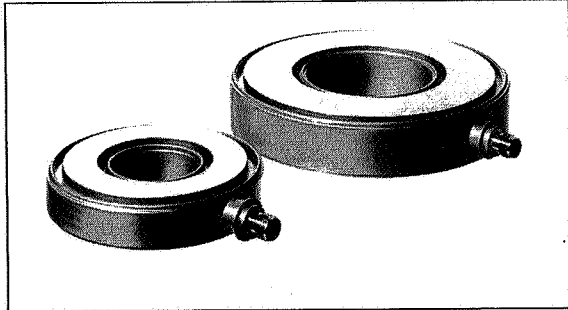

Figure 9. Industrial piezoelectric load washers

Extremely fast events such as shock waves in solids, or impact printer and punch press forces can be measured with these devices when otherwise such measurements might not be achievable. Piezoelectric sensors operate with small electric charge and require high impedance cable for the electrical interface. It is important to use the matched cabling supplied with a transducer.

Piezoelectric crystal sensors are primarily designed for applications using a pre-tensioned bolt which allows the measurement of forces in both tension and compression. Mounting of a load washer in this way is illustrated in Figure 10. The pre-loading is important to ensure optimum linearity and the sensor must be calibrated after mounting.

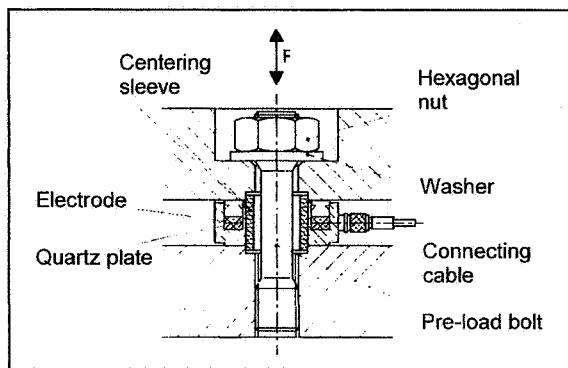

Figure 10. Mounting of a load washer

An extension of this principal is the use of *force measuring pins* which are placed within the structure of a machine and respond to the forces within the structure.

There is a small leakage of charge inherent in the charge amplifier, which is called drift of the signal. So while piezoelectric force transducers are ideally suited for dynamic measurements they cannot perform truly static measurements. Measurements can be made over a period of minutes or even hours and piezoelectric transducers are said to take 'quasi-static' measurements.

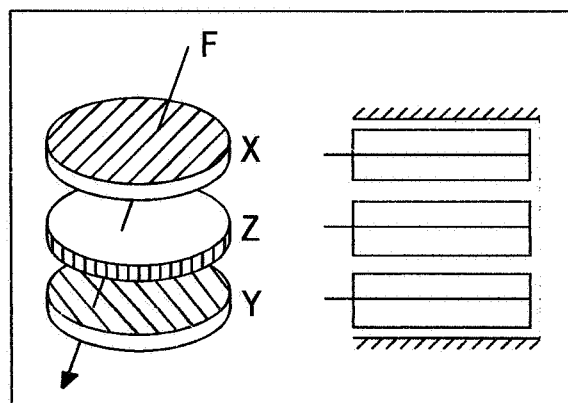

Figure 11. Multi-component crystal force sensor

Piezoelectric crystal sensors are suitable for measurements in laboratories as well as in industrial settings. The measuring range is very wide and the transducers survive high overload (typically > 100 % of full-scale output). The sensors' small dimensions, large measuring range and rugged packaging makes them very easy to use. They can operate over a wide temperature range and survive temperatures of up to 350°C.

Multi-component piezoelectric force transducers measure the forces in three orthogonal axes. Figure 11 shows the operating principle of such a transducer

Force F acts upon the transducer and is transmitted to each of 3 discs with the same magnitude and direction. Each piezoelectric crystal ring (shown 'exploded' in the figure) has been cut along a specific axis and the

orientation of the sensitive axis coincides with the axis of the force component to be measured. Each then produces a charge proportional to the force component specific to that disc. The charge is collected via the electrodes inserted into the stack (see lower right drawing in the figure).

4.4 Measuring force through pressure

4.4.1 Hydraulic load cell

The *hydraulic load cell* is a device filled with a liquid (usually oil) which has a pre-load pressure. Application of the force to the loading member increases the fluid pressure which is measured by a pressure transducer or displayed on a pressure gauge dial via a Bourdon tube.

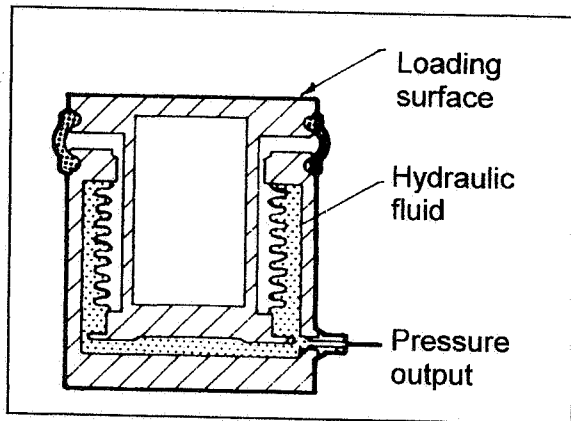

Figure 12. An example of a hydraulic load cell.

When used with a pressure transducer, hydraulic load cells are inherently very stiff, deflecting only about 0.05 mm under full force conditions. Although capacities of up to 5 MN are available, most devices fall in to the range of 500 N to 200 kN. The pressure gauge used to monitor the force can be located several metres away from the device by the use of a special fluid-filled hose. In systems where more than one load cell is used a specially designed totaliser unit has to be employed.

Hydraulic load cells are self-contained and need no external power. They are inherently suitable for use in potentially explosive atmospheres and can be tension or compression devices. Uncertainties of around 0.25% can be achieved with careful design and favourable application conditions. Uncertainties for total systems are more realistically 0.5-1%. The cells are sensitive to temperature changes and usually have facilities to adjust the zero output reading, the temperature coefficients are of the order of 0.02% to 0.1% per °C.

4.4.2 Pneumatic load cell

The operating principles of the *pneumatic load cell* are similar to those of the hydraulic load cell. The force is applied to one side of a piston or a diaphragm of flexible material and balanced by pneumatic pressure on the other side. This counteracting pressure is proportional to the force and is displayed on a pressure dial.

The sensing device consists of a chamber with a close-fitting cap. The air pressure is applied to the chamber and builds up until it is equal to the force on the cap. Any further increase in pressure will lift up the cap allowing the air to bleed around the edge until pressure equilibrium is achieved. At this equilibrium position the pressure in the chamber is an indication of the force on the cap and can be read by the pneumatic pressure dial gauge.

4.5 Other types of force measurement system

4.5.1 Elastic devices

The *loading column* is probably the simplest elastic device, being simply a metal cylinder subjected to a force along its axis. In this case the length of the cylinder is measured directly by a dial gauge or other technique, and an estimate of the force can be made by interpolating between the lengths measured for previously applied known forces. The *proving ring* is functionally very similar except that the element is a circular ring, and the

deformation is usually measured across the inside diameter. These transducers have the advantage of being simple and robust, but the main disadvantage is the strong effect of temperature on the output. Such methods find use in monitoring the forces in building foundations and other similar applications.

The **linear variable differential transducer (LVDT)** may be used within a load cell to measure the displacement of an elastic element instead of using strain gauges. The LVDT is essentially a transformer which provides an alternating current (AC) output voltage as a function of the displacement of a separate movable magnetic core. The lack of friction and the low mass of the core results in high resolution and low hysteresis, making this device ideal for dynamic measurement applications.

Capacitive load cells use a capacitance sensor to sense the displacement of an elastic element. In most cases the sensor consists of two parallel plates standing opposite each other. The changing length of a spring member produces a change in the gap between two plates, and hence a change in electrical capacitance. In the case of small weighing instruments such as domestic scales, the spring also provides parallel guidance of the scale's platform.

An **optical strain gauge** can be formed in a manner similar to a wire strain gauge by the use of optical fibres. The deflection of the elastic force-bearing member with the optical strain gauge bonded to it will result in length changes in the optical fibres. If monochromatic light is used to feed two optical strain gauges experiencing different strain levels then the phase difference between the two beams emerging from the gauges, in number of half wavelengths, is a measure of the applied force.

The **interference-optical load cell** uses a high-resolution displacement measuring method. A fork-shaped spring is deformed by the force, the deformation being in the region of 40 μm , and the change of the aperture of the fork is measured by a Michelson interferometer. For the same resolution, the maximum elastic deformation and with it the strain of the material need not be as large as in the case of the strain gauge load cell. The deformation element is made of quartz (silica glass) with very small temperature dependence. Any residual error may be corrected by the use of a temperature sensor and computer. These systems have a limited temperature range from 5 $^{\circ}\text{C}$ to 40 $^{\circ}\text{C}$ for an overall performance better than 0.01%, and the hysteresis and creep are both particularly small. Optical systems based on Moiré fringe measurements are also manufactured.

4.5.2 Vibrating elements

In the case of the **tuning-fork load cell**, the force transducer consists of two parallel band splines which are connected at their ends and vibrate in opposite directions in resonance. The mode of vibration is like that of a tuning fork and the resonant frequency changes if the element is subjected to a tensile or compression force. The excitation of the vibration and the reciprocal reception of the vibration signals are carried out by two piezoelectric (see Section 4.3) elements close to the vibration node of the tuning fork. The tuning fork is typically about 25 mm long and made of Elinvar (Nickel steel with 13% Chromium), with a rated capacity of 8 N, a resonant frequency of 6 kHz to 7 kHz and a linearity performance of between 0.01% and 0.02%

The **vibrating-wire transducer** consists of a taut ferromagnetic wire that is excited into transverse vibrations by a drive coil. These vibrations are detected using a pick-up coil. Both coils have permanent magnet cores and once the wire has been excited to its resonant frequency for a given tension, it is maintained at this frequency by connecting the two coils through an amplifier to form a self-oscillating system. Each resonant frequency is a measure of the wire's tension and hence, applied force at that instant. The advantage of the vibrating wire transducer is its direct frequency output which can be handled by digital circuitry eliminating the need for an analogue-to-digital converter. The vibrating wire principle is used to measure force in pressure transducers and strain levels in civil engineering applications.

In the **surface-wave resonator** load cell, an ultrasonic transmitter which is actuated by alternating voltage and consists of comb-shaped electrodes on a quartz substrate, emits surface sound waves directed according to the inverse piezoelectric effect. A second system which is arranged in the same way converts these sound waves back into an alternating voltage, according to the piezoelectric effect. The amplifier is so arranged that the

system vibrates in natural frequency. The deformation of a spring, which depends on force, changes the resonator frequency.

4.5.3 Magneto-elastic devices

The *magneto-elastic force transducer* is based on the effect that when a ferromagnetic material is subjected to mechanical stress, the magnetic properties of the material are altered and the change is proportional to the applied stress. Due to the sturdy construction, high signal level and small internal resistance, the magneto-elastic load cell can be used in rough and electrically disturbed environments such as in rolling mills. The rated capacities of these devices is in the range from 2 kN to 5 MN.

4.5.4 Dynamic balance devices

Gyroscopic load cells exploit the force sensitive property of a gyroscope mounted in a gimbal or frame system. A commercially available gyroscopic load cell incorporates a dynamically balanced heavy rotor on a spindle, itself mounted in the inner frame of a two-gimbal system. The arrangement has three axes of rotational freedom mutually at right angles and has the axis of origin on the centre of gravity of the rotor. The force to be measured by the transducer is applied through the lower swivel and a couple is produced on the inner frame causing the gimbals to precess. The time taken for the outer gimbal to complete one revolution is then a measure of the applied force. The gyroscopic load cell is essentially a fast responding digital transducer and is inherently free of hysteresis and drift.

The *force balance* uses a feedback circuit to compare the electrical output to the force input. A typical system has attached to the force input member an electrical coil which operates in the flux gap of a permanent magnet. An electric current passed through the coil generates a restoring force in opposition to the applied force. A displacement transducer is used to sense the displacement of the force input member, its output being amplified and used to control the current in the coil until the restoring force exactly balances the applied force and restores the force input member to its original position. The coil current to achieve this balance is proportional to the applied force and is measured as a voltage sensed across a resistor in series with the coil. This type of device has good dynamic performance, small deflection and relative insensitivity to environmental conditions. They are inherently stable and accurate and as a result are often considered for the use as secondary standards. This type of device is mainly a competitor for the mechanical analytical balance in mass determination.

4.5.5 Plastic deformation

Plastic deformation may be used as a method of permanently recording an applied force. The force is applied to a small (usually metal) element which suffers permanent deformation beyond the elastic limit of the material. The deformation for a particular size, shape and material properties may be calibrated by testing of similar elements.

5 APPLICATIONS

5.1 Range of applications

Force measurement systems are widely used in different industries. It is difficult to describe every possible use, so the applications listed here are designed to give a representative view of the types of application that users of force measurement systems may encounter. Rather than grouping the applications by industry it is probably simpler to group them by where in the production cycle they occur: in research and development, during the manufacturing process, or during the installation, testing and use of a product.

Frequently force measurement is part of the safety system of the associated process and may be part of the quality control of the base, intermediate or end product. The measurement may be destructive, such as a materials testing machine checking material stress/strain characteristics, or non-destructive such as checking machine or product performance.

In every case the particular application or industry will require specialist knowledge in designing and using force measurement systems. It is important to consult the right people (product specialists, manufacturers etc.) before embarking on an unfamiliar application. Guidelines for the choice, installation, calibration and use of force measurement systems for any sort of application are given in Sections 6 and 7.

5.2 During development of a product

5.2.1 Materials testing machines

Force transducer systems are commonly fitted to *materials testing machines* to monitor the load whilst testing specimens of material to ascertain their stress/strain or fatigue characteristics. These machines usually work along a single axis and may apply tension or compression forces or both. Some machines are specially designed to apply loads in 2 or even 3 axes simultaneously. Because they are well-controlled and widely used machines for the application of force, materials testing machines are also frequently used in the general calibration of force measuring systems, see Section 7.2 for more details.

5.2.2 Component testing

Component testing is important in many industries, particularly the aerospace and automotive industry. The components, larger parts of the structure and sometimes the complete structures are tested under simulated in-service conditions. Measurements may be made of the applied forces and the forces within the structure, and this may involve the use of standard load cells, or may need specific fitting of strain gauges or force-measuring pins directly onto the structure being tested.

5.2.3 Gas turbine thrust measurement

Measurement of *gas turbine thrust* is one of the three main parameters needed to define the power output and efficiency of aero-engines, the other two parameters being rotational speed and fuel consumption. The levels of uncertainty required are very low, and this application is one of the most demanding on force measurement. The engine is mounted horizontally in a specially designed cradle that is either supported directly with shear beam force transducers or is supported on low friction flexures with force transducers mounted horizontally to measure forward (and sometimes reverse) thrust generated by the engine in the frame.

5.2.4 Torque measurement on engines, pumps and gearboxes

To measure the efficiency and *torque* output of a motor it is common to drive it into a rotational absorption device such as a water brake, or into an electric motor used as a generator. The absorption device is mounted between trunnion bearings so that it is free to rotate around the input drive shaft. A mechanical arm is then attached to the body of the motor/brake to restrain the rotation via a force transducer attached to its other end.

The force transducer measures the force at a known distance on the end of the arm and thus the torque output of the engine can be calculated. In the case of pumps and gearboxes an AC or DC motor is used in the drive (rather than absorption) mode to measure the torque necessary to drive the pump or gearbox and thus its losses and efficiency can be ascertained.

5.3 During the manufacturing process

5.3.1 Cable laying

Large amounts of cable are laid around the world, either sub-sea or in trenches into the ground. Such cables may be copper or fibre-optic, and the force applied to them needs to be monitored and controlled for the efficiency of the operation and to assure the cable is not over-stretched. *Cable laying* winches normally take the cable from a drum, and a linear engine handles the cable by gripping it between opposing pairs of wheels. The cable usually enters and leaves in or near the horizontal axis.

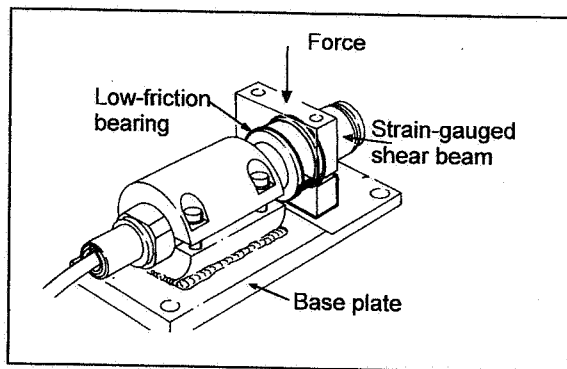

Figure 13. A shear pin force transducer

To measure the tension force, which is the reaction between the machine and the mounting deck, the winch or linear engine handling the cable is supported directly on *shear pin force transducers* (see Figure 13) with their measuring axes horizontal. If on board ship, compensation for the pitching of the ship must be made to correct for the fluctuating forces acting on the machine.

5.3.2 Undersea pipe-laying

Measuring *pipe-laying tension* is a similar application to cable laying with a linear engine, again on board ship, but the pipe is handled by opposing pairs of caterpillar tracks. The frame of the apparatus is supported on shear pin force transducers to measure the tension force in the pipe. In this case there is the added complication that the linear engine may be mounted on a tilting frame or tower so that the pipe can enter the sea at the stern of the vessel at any predetermined angle between horizontal and vertical.

5.3.3 Web tension measurement

In the paper, plastic film, laminates and metals industries force transducers are mounted under the bearings of one of the rollers in the web path to measure the force generated by the web, and thus display the *web tension*. Alternatively some designs of force transducer allow support of the axles of the roll directly and can be rotated to be in line with the maximum component of force generated by the tension. (See the worked example in Section 9.1).

5.3.4 Rolling mill forces in the metals industry

Measuring the forces acting on rollers during *metal rolling* is important for both the product quality and safety of the operation. The system design is similar to that described for web tension measurement, but the force transducers under the bearings measure the separating forces between opposing rolls. Another method is to mount an extensometer on the frame of the machine, thus using the frame in the same way as the elastic element in a transducer. The environmental demands on the transducer in terms of temperature, vibration, and dust may be very severe.

5.3.5 Sheet metal pressing

When *pressing sheet metal* and other materials, force transducers may be fitted in to the press so that the optimum forces applied to the component being manufactured can be measured and controlled. See the worked example in Section 9.2.

5.3.6 Cutting Tool Forces

Certain high-speed fine machining operations require a knowledge of the forces acting on the cutter in order to maintain optimal performance. A four-component dynamometer may be fitted onto the rotating tool spindle to measure *cutting force and torque*. Strain-gauge systems have been used in this application, and a quartz device is commercially available. A large range of frequency response and high stiffness of the transducer are key factors in determining the usefulness of a transducer in such an application.

5.3.7 Measuring drilling forces in the oil industry

Oil and gas wells are drilled by mounting a cutting bit on a long piece of pipe which is weighted at the end and suspended from a mast or derrick. The total force must not exceed the load capability of the mast, nor exceed the tension strength of the pipe when pulling out of hole against possible sticking forces in the hole. The *drilling force* applied to the bit is the total weight of drill string in the hole less the hook load, and this is critical in maintaining optimum drilling efficiency. Force measurement in operation is therefore vital in many respects. The measurement is accomplished by either mounting a force transducer in the anchor point of the multi-drop ropes that support the main drill string support hook, or more accurately, by mounting force transducers under the complete crown block assembly at the top of the drilling derrick.

5.4 Systems that measure or control force for safe operation

5.4.1 Ship and tanker mooring forces

Mooring forces of ships frequently need to be monitored. Tension force transducers can be mounted in line with the mooring ropes, or more commonly shear-pin force transducers may be built in to the clevis block mountings.

5.4.2 Tension leg platforms

Tension leg platforms are floating offshore structures, usually for petroleum drilling or production, which are moored to the sea bed via flexible legs. The legs have multiple combinations of high capacity force transducers in parallel so that the tension in each leg is monitored and can be controlled and equalised by appropriate ballasting.

5.4.3 Crane overload/underload protection

To monitor the forces acting on a crane hook, the anchor point for the hook support cable or a compensating sheave or pulley on the crane may have load cells built in to them. Depending on the arrangement, the transducers may act in tension or compression. There is usually a warning given if an attempt is made to lift a load in excess of the rated capacity of the crane. There is often also a requirement for low load warnings (called "slack rope") to stop the grab or bucket being lowered so that it touches the ground and then tips over tangling the support ropes. On mobile cranes the load being lifted is taken along with jib angle, jib length and other mechanical characteristics to compute turning moments and activate an alarm before the crane becomes unstable and tips over.

5.5 Process weighing

5.5.1 Force measurement in weighing

Determining the mass or weight of a product is often a key step in a manufacturing process, and is known as **process weighing**. Batch mixing, lorry loading, packing and vessel filling of liquids, gases or solids are all processes requiring accurate determination of weight. The user is referred to the associated 'Guide to the Measurement of Mass and Weight' [26] for a comprehensive guide to weighing, but many process weighing situations use load cells to measure forces from which the weight of product is derived.

Good practice in using force measurement for weighing is similar to other force measurements, and the user may apply the guidelines given in the present document. One pitfall however is that while determination of the force may be straightforward, the interpretation of the gravitational component acting on the mass may not be so simple, as shown by the following example of vessel weighing.

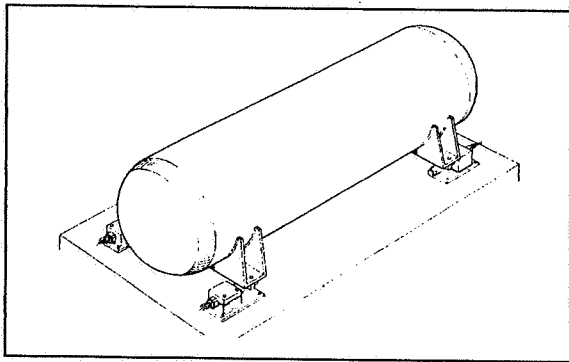

Figure 14. Vessel supported by four load cells

5.5.2 Vessel weighing

If a vessel can be mounted at all support points on force transducers, and if the associated pipework and fittings do not take some of the force, then the weight may be derived from the total force measured. Figure 14, for example, shows a tank supported on four load cells. Often, however, to reduce cost the vessel may be mounted on one load cell and two dummies, or two load cells and two dummies, and the force is assumed to be equally distributed between the active and non-active points.

Weighing of a 3 legged tank/vessel with one active force transducer in this way leaves the measurement at the mercy of variations in centre of gravity due to non-level loads, non-uniform vessel cross-section, agitation of the contents and external wind forces. Accuracy of weighing with these systems is usually poor (although acceptable sometimes for level measurement) even if the material in the tank is self levelling or a liquid. The effects of pipework, fittings and non-linear deformation of the tank will cause movement of the centre of gravity between the empty and full conditions as well as affecting the total force seen by the measurement devices.

5.5.3 Road traffic axle loads

The measurement on-board a vehicle of the force acting on each of the axles (known as **axle load**) is important for safety of the vehicle and the highway infrastructure. Such systems are not for the determination of mass, although they are for the measurement of force due to gravity.

5.6 Requirements on uncertainty

Requirements of measurement uncertainty vary with the application and even within the industry for the same application. The need for lowest uncertainty is in the area of force transfer standards where uncertainties no greater than 0.005% fso and repeatability of 0.001% fso or better are required. One of the most stringent requirements in this area is the inter-comparison of deadweight machines and also calibration of mass weights. Lowest requirements on uncertainty are with overload protection systems such as crane overload protection, winch mooring and weighing without fully supporting the vessel where 5-10 % fso is frequently acceptable. Normally the uncertainty in most of the other applications will be from 0.1 to 2 % fso.

6 CHOICE, DESIGN AND OPERATION OF SYSTEM

6.1 Choice of force measurement system

It can be seen from the previous section that there is a wide range of applications for force measurement in many different industries. The choice of force measurement system can only be made after considering the specific details of the application. The designer should consider the range of force to be measured, the number of loading points, the direction of the forces (and whether in tension, compression or both) and the duration and rate at which the force is applied to the transducer. As a result of these considerations the choice can be made on what type of transducers can be used, how many will be required and of what capacity, whether uni- or bi-directional and whether single or multi-axis.

The choice of instrumentation also needs to be made. The frequency and amount of data to be collected need to be considered as well as the nature of the indicator and any links to a data acquisition or control system.

The design of the force measurement system must meet the required limits of uncertainty, considering the uncertainties from each system and calibration component. Although a particular installation may require several transducers, the text here will refer to transducer in the singular – the implication is that in an installation with more than one device, the considerations will apply to all of them.

6.1.1 Transducer operating capacity

Normally the transducer should be chosen such that it can be operated within its design loading range. Careful consideration should be given to potential overload events that may occur since overloading the transducer could bias the transducer's calibration, especially under dynamic loading.

6.1.2 Single or multiple transducers

The decision on the number of transducers to be used can be influenced by several factors. These factors include consideration of the space available, total capacity requirement and the capacities of load cells available, number of loading points, accuracy requirements and cost restraints. Placing transducers at all points of loading will reduce the uncertainty compared to using pivots or dummy load cells at some of the loading points and will minimise the effects of off-centre loading and bending forces (see the discussion on process weighing in Section 5.5 for example). Using several transducers may be necessary to get the capacity required, or may be beneficial to minimise the range of different devices to be supported but using multiple transducers may incur extra costs due to additional data collection channels and calibration.

6.1.3 Uni-directional or bi-directional transducer

The choice of using a *uni-directional* or *bi-directional* force transducer is required when both tension and compression forces are to be measured on the same rig or machine. The obvious choice of a bi-directional transducer has the advantage that less transducers are required and mounting is simple. However, a disadvantage is that measurement uncertainty may increase as the zero force point is approached. Note that transition across zero will introduce additional uncertainty. In certain situations requiring low uncertainty, the use of two unidirectional transducers pre-loaded against each other may be considered but the design of such a system is complex. When bi-directional forces are to be measured, it is important that the system is stiff, and that the zero force point is well-defined mechanically, with low backlash.

Many applications for force measurement involve the fitting of a transducer in a tension/compression strut, which naturally lends itself to the fitting of a single in-line transducer within the length of the strut or possibly a pin/clevis type at one end. Measuring pins, shear beams and pre-loaded force washers are all particularly suited for bi-directional force measurement.

6.1.4 Static or dynamic measurement

The force measurement system must be capable of measuring the rates of change of force which are anticipated. Any transducer used should have a natural frequency of response which is well above the maximum frequency expected in the application. As described in the description of the different sorts of transducer, some transducers (such as piezoelectric crystal) are inherently better for high frequency measurements. For long-term stability in static measurements foil strain gauge and vibrating wire transducers are particularly stable.

6.1.5 Multi-component force measurement

Where several components of force are to be measured, the system may comprise uni-axial transducers aligned to each required axis, or use a multi-component transducer. Multi-component force transducers have a variety of forms from bi-axial through tri-axial to 6-component 'sting' balances that can measure on three axes and also torque in each axis. A multi-component piezoelectric crystal force sensor was described in Section 4.3.

Depending on the measuring range and force footprint, it may be possible to use a single multi-component force sensor to solve a certain measurement problem. When larger sizes and/or ranges are necessary, a so called *force dynamometer* might be required consisting of a mechanical packaging of usually four multi-component force elements and specific wiring of the force signals. See Section 9.4 for an example of the use of a type of force dynamometer.

6.1.6 Instrumentation and data collection

As discussed in Section 4, the instrumentation associated with a force transducer may range from the very simple to the extremely complex. Each type of transducer has particular types of instrumentation associated with it and some examples are given in Table 4. The instrumentation may contain a number of separate

elements and some possible combinations are shown in Figure 15.

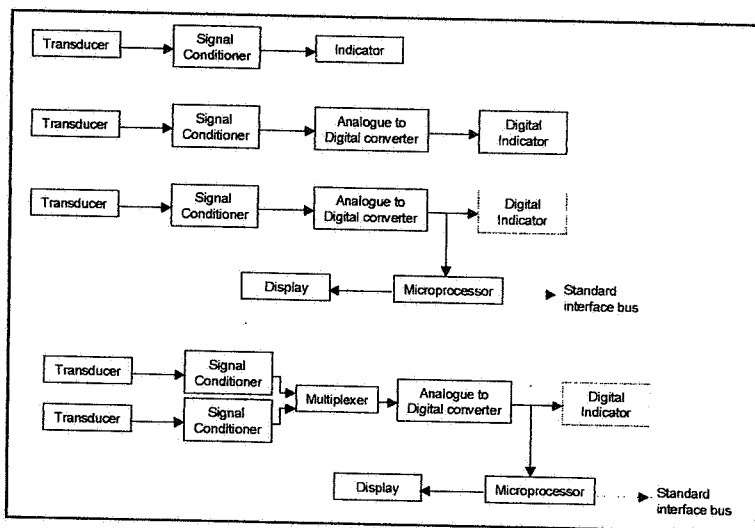

Figure 15. Typical instrumentation combinations

There is normally an indicator on the instrument which may give the value of the measurement in units of force (in which case there will be an internally-set calibration applied) or in non-force units such as mV or mV/V. Also the instrument may be required to communicate the output directly to a data acquisition system or control system. Such output may be analogue or digital.

Analogue output is normally 0 to 5 V in laboratory instrumentation systems and 4 to 20 mA for industrial use. **Digital output** is normally via a standard electronic communication system known as a *bus*, such as IEE488 or RS232, where the standard specifies the type of connectors, the signals available and their location on the connectors. The use of standard buses enables different instruments to be easily added to a network.

Data collection in a force measurement system is of particular importance in the measurement of rapidly changing forces. The design must accommodate the technical requirements addressing the speed, period and volume of data. The susceptibility of the system to developing undetected errors between calibrations should be considered. This can be alleviated by building in redundancy, typically by using two similar force measurement transducers to cross reference their measurement. Monitoring multiple channels can introduce reading uncertainties due to *slew* (the fact that all the channels cannot be read at the same time and the force has changed slightly between readings of the different channels). Slew can be eliminated by using sample and hold techniques.

Table 4. Instrumentation associated with common transducer types

Transducer type	Output	Typical instrumentation
Loading column, proving ring	Deflection (length)	Dial gauge
Strain gauge load cell	Voltage	Voltmeter. Often combined with the transducer power supply and output digital indicator.
Piezoelectric	Charge	Charge amplifier
Hydraulic, pneumatic load cell	Pressure	Pressure gauge, traditionally Bourdon tube.

6.2 Design considerations

6.2.1 Safety

The design of a force measurement system must include the necessary *safety requirements*. This guide cannot be specific for a given installation and the user must be fully responsible for all safety requirements of any particular application. The statements in this document are designed to act as an aide-memoire for the user, who should also consult the norms and standards for his or her specific industry and installation. The design of an installation should address the potential hazards produced by the use, containment and transportation of energy in its many forms. Consideration should be given to these hazards within the force measurement system and its associated rig, in conjunction with the compatibility and needs of the surrounding areas and processes. Potential safety hazards may include electrical, hydraulic, heat, radio frequency, chemical or light energy sources.

When a force measurement system is to operate in a potentially explosive atmosphere appropriate design rules must be used and an *intrinsically safe operating system* should be considered. Information on this specialist subject can be found in [37].

In the case of fluctuating forces, the natural frequency of the load cell and its mounting should be much greater than the frequency imposed or the system may fail catastrophically.

6.2.2 Environment

The *environment* in which the force measurement system has to work can have a significant effect on its performance. Parameters to be considered include the temperature, vibration, humidity, corrosive nature of the atmosphere, variation in ambient pressure and freedom of movement required by the displacement of all the force measurement transducers.

The protection of a force transducer against penetration by foreign objects (including hands and tools, dust etc.) and ingress by moisture is normally given by an *IP code*. So, for example, a force transducer coded IP56 is dust protected (first numeral 5) and protected against powerful water jets (second numeral 6). A device coded IP10, though, is protected against the ingress of a solid foreign object of greater than 12.5 mm diameter or a finger of 12 mm diameter (first numeral 1) but not protected at all against water ingress (second numeral

0). The user is referred to BS EN 60529 [15], or manufacturer's literature, for more details on environmental protection levels.

Temperature becomes an issue when the temperature limits of the force measurement system and its transducers are approached or exceeded. In this case measurement of the transducer's temperature and its environment must be made. Both the actual temperature and rate of change should be measured. The latter is important as temperature gradients may occur which could significantly affect the accuracy of the force measurement reading. To monitor temperature gradients a multiple sensor temperature measurement system should be employed.

Vibration induced in the force measurement system should be considered. The design should ensure that vibration is maintained within the specified operating limits. The effects of humidity and corrosive atmosphere on the force measurement system can be addressed using standard industrial techniques.

6.2.3 Installation space

The design must allow space for *installation*, calibration and maintenance of the force measurement system and any auxiliary components such as the transfer standard, temperature regulation equipment, telemetry data or control links. The design may also need to allow for position feedback transducers for monitoring or control purposes, specific lifting or manoeuvring equipment, space lighting or safety equipment including possible interlocks and isolation systems.

6.2.4 Force transducer mounting

The location of the test piece, rig and transducer alignment need to be assessed. This is to ensure that during normal operation unnecessary side forces and twisting moments cannot be introduced and that the optimum loading position is used.

Freedom of movement is essential over the operating range of applied force, this should be in both directions if bi-directional forces are to be measured. The design should also ensure that there are no parallel load paths (known as *force shunts*) which may take some of the force that is supposed to be measured by the transducer. Force shunts can be present all the time (such as through pipework connections) or may occur when the movement of the system is arrested by overload stops.

The end fittings of the transducer should be designed to minimise side loads, and to allow the force to be passed to the transducer along a well-defined axis, normally the principal axis of the transducer. The interface at which the transducer is removed from its mounting on the rig for calibration purposes should if possible not involve any removal or adjustment of any threaded fitting on the force transducer itself.

6.3 Operating the force measurement system

The way the force measurement system is operated can have a significant effect on the uncertainty achieved. Care needs to be taken that the instrumentation and power supplies are allowed time to *warm up* before use (usually some tens of minutes), and that the temperature of the transducer and installation is stable. Sometimes thermal gradients can introduce extra uncertainty even when the process is in steady state.

It is good practice to monitor the output at zero force as a regular check. This check is particularly good at determining when the transducer may have been overloaded and its calibration affected. It is important to ensure that zero force is truly zero and repeatable. If zero force is not suitable, then some other mechanically well-defined check force may be used.

Care should be taken in laying out cables so that electromagnetic effects or thermally-induced voltages are not introduced into the system.

A **shunt calibration** may be performed on strain gauge load cells to check the installation by switching a resistor across one arm of the wheatstone bridge (this was shown in Figure 7). This puts a known offset onto the bridge output to simulate a load that has been determined at the time of calibration of the transducer by the manufacturer. Individual values are needed for each transducer, and some manufacturers will only supply these to special order. A shunt calibration is a useful check on the performance of the electrical part of the system, but is not a substitute for a force calibration. Special attention should be made to connections and cables for the shunt calibration, otherwise significant errors may occur. If the cable is cut or extended then a correction factor should be applied according to the supplier's instructions. The best uncertainty that can be expected from a shunt calibration is 0.2%, but this can not be assumed unless the system has been very carefully evaluated.

The data may still suffer corruption even after acquisition, and care should be taken to ensure that the raw unprocessed data is stored in addition to values which have been mathematically manipulated with calibration factors and so on.

In high accuracy applications it may be necessary to check the correct operation of the force measurement system before and after critical events. Where possible these checks should identify the magnitude of error from each source. Typically these take the form of drift and noise in the conditioning system, non-linearity and hysteresis in both the conditioning equipment and force transducer and creep from the force measurement transducer. The checks should also identify the errors produced by the system's mountings which can take the form of stiction, limitation of free movement and other unwanted loading effects. Such confidence checks should be a part of the maintenance programme carried out on a daily, weekly or monthly basis. Continuous checks should also include evidence that the force transducer and its environment have been maintained within the required limits.

6.4 General Do's and Don'ts

6.4.1 Do's

Do make sure you understand the definitions of the specifications that are used by the manufacturers of the force measurement system you intend to use.

Do make sure that the rated capacity of the force transducer is equal to or greater than the applied forces.

Do consider the whole measuring range needed. What are the largest and smallest forces you expect to measure? If you do not know, a transducer with large measuring range and high overload is of benefit.

Do consider inclined forces and the resultant **side forces** present in the application and the capability of the force transducer to withstand them and measure to the required uncertainty in their presence. It does not mean that if a device has a specification that says it will withstand 100% side force that this side force will not affect, to some degree, the measurement of the force acting along the principal axis.

Do consider the effect of dynamic forces in the application. The rating of the transducer must encompass these forces within its normal working range or some means of protecting the load cell must be designed in. A **dynamic overload** beyond the safe overload of the load cell will damage it just as surely as a static one.

Do consider the working environment that the transducer will be subject to, consider temperature, humidity, water splash and potential mechanical abuse.

Do consider if any of the force to be measured is taken by force shunts such as supports, bearings, flexures, pipes etc. causing errors which may be impossible to calibrate.

Do consider the mounting of the sensor. The quality of the measurement signal depends on the correct mounting of the sensor in the machine structure. Does the mounting minimise the impact on the machine construction?

Do consider how easy it is to calibrate and test the mounted sensor or the whole set-up. Although, correctly mounted, sensors may have a long lifetime, it is better to consider also how to dismount them later, as the sensor might be used again.

Do choose an appropriate data acquisition rate. Filtering and signal conditioning (e.g. amplifier settings, low/high pass filters, software) need to be set correctly.

Do, if you use a piezoelectric force sensor, put the amplifier into 'operate' either manually or triggered through switches before each measurement to give repeatable measurements.

6.4.2 Don'ts

Don't design or use a load cell where the applied forces (static or dynamic) normally encroach into the safe overload capacity of the transducer.

Don't lay connection cables alongside cables carrying power or large switching currents.

Don't lay cables where they can be damaged by fork-lift trucks or other vehicles operating in the vicinity.

Don't change the cable length if a transducer is supplied with one fitted – such changes may affect the system calibration.

Don't allow ingress of moisture or contamination to the connections either at the transducer, junction boxes or instrument.

Don't pick up a transducer by its cable, if it has one.

Don't forget to include purchase price, lifetime, installation and calibration costs of transducer, amplifiers and the whole measuring chain when comparing costs.

Don't design an installation with multiple force paths unless they are all measured or the position of force application is well controlled.

6.5 Working with the supplier

It is always advisable, if possible, to consult the supplier of the force transducer about the proposed force measurement application. The supplier will be able to advise on selection of the most appropriate transducer for the circumstances and will often be able to provide additional application information to that which appears in a standard data or specification sheet. In particular, the supplier will be able to advise on the way the force is applied to the transducer and a mounting arrangement which will ensure that the best measurement uncertainty is achieved.

The transducer manufacturer will also advise on other aspects referred to earlier in this chapter, such as overload behaviour, environmental protection and, if appropriate, dynamic considerations such as shock load behaviour, deflection, response and fatigue life.

The manufacturer may be prepared to customise the mechanical or electrical specification of a standard transducer if this is necessary to satisfy the application requirements and may be able to offer calibration certification or a re-calibration service.

Before discussing any requirements with a manufacturer it will be helpful to run through the application to understand the requirements. Table 5 summarises features which may be required in many force measurement applications, and which should be considered for any new installation.

Table 5. Check list of potential requirements for a force measurement system

<p>Force Applied Maximum force Working force range Zero offset Overload requirement Static/dynamic load Uncertainty required Side load Inclined load Bi-directional load Multi-axis load Fatigue rating Vibration levels</p> <p>Mechanical Deflection Load cell orientation Change of orientation Equal load sharing No. of loading points Flexures/ restraints Direct loading Pivots Dirt build up</p>	<p>Calibration Load cell System Direct/indirect Deadweight Transfer standard Shunt</p> <p>Environment Wet/humid Immersion Dust Specific sealing required Corrosive Hazardous Temperature range Hygienic</p> <p>Instrumentation Analogue/digital Resolution Local/remote display Repeat display</p>	<p>Supply - mains AC - low V DC - battery</p> <p>Trip points Housing Outputs Voltage sensing Cable length Electrical noise Hazardous area Filtering</p> <p>System Configuration Single bridge Load share adjustment - mechanical - electrical</p> <p>Instrumentation Junction box Load cell connection - cable - connector</p>
--	---	--

7 CALIBRATION

7.1 Overview

The previous chapters have covered the choice, operation and design of force measurement systems and their installation. But even with good transducers and a good system design, the measurement cannot be relied upon without some check on the performance of the system. Unexpected installation effects, degradation of the equipment over time or user abuse may all lead to a measurement which has a greater uncertainty than the designer planned. Consequently *calibration* is required to ensure that the force measurement meets the needs of the user and achieves the required degree of uncertainty.

The calibration of a force measurement system requires an understanding of traceability, standards, options, procedures and analysis of the data. This chapter covers those subjects in that order.

7.2 Standards and traceability

Traceability to authoritative standards is the best way to ensure accuracy of measurements, and leads to consistency of measurements among users at different times and locations. A traceable measurement is one which can be related to a primary measurement standard through an unbroken chain of comparisons.

A standard force is less easy to visualise than a standard mass and by its nature must be created by a machine rather than having a separate existence as an artefact. Not only must the magnitude of the force be known to the required uncertainty, but also its direction and the conditions of its application to the transducer under test.

Machines capable of undertaking force calibrations are known as *force standard machines* and they may be categorised as either primary or secondary. *Primary standards* in force measurement are machines whose uncertainty can be verified through physical principles directly to the fundamental base units of mass, length and time. *Secondary standards* are machines which can reliably reproduce forces and can be compared to primary standards by the use of a *force transfer standard* which is a calibrated force transducer, frequently a strain gauge load cell. Types of force standard machines and their characteristics are given in Table 6. The instrumentation used during the calibration must itself have full traceability, either by calibrating the complete force measuring system of transducer and instrumentation together, or separately for the calibration instrumentation.

Primary standards are usually defined at a national or international level by a single authoritative measuring instrument known as a *national standard* or *international standard*. Traceability normally means that the calibrations have been undertaken by the national standards laboratory (e.g. NPL in the UK), by an accredited laboratory (e.g. NAMAS), or by a national or accredited laboratory in another country with which there is a reciprocal recognition agreement.

Most documentary standards in the area of force measurement were written to satisfy a need for traceability in materials testing. The procedures contained in these standards are also used for the calibration of force measurement systems in a wide range of other industries. The calibration, or verification, of *materials testing machines* is covered in the UK by BS 1610: Part 1 [2] for machines operating in compression and by BS EN 10002-2 [10] for machines operating in tension. The documents dealing with the calibration and classification of transfer standards (or *force proving instruments*) are BS EN 10002-3 [11] and its ISO equivalent, ISO 376 [20]. In the case of transfer standards, any particular calibration may result in an *interpolation classification* for which equations linking force to deflection are calculated and stated in the certificate, or a *specific forces classification*, which only enables the instrument to be subsequently used at the calibration forces.

Table 6. Types of force standard machine

Machine Type	Principle of operation	Uncertainty attainable	Category
<i>Deadweight machines</i>	A known mass is suspended in the Earth's gravitational field and generates a force on the support.	±0.001%.	Primary or Secondary
<i>Hydraulic amplification machines</i>	A small deadweight machine applies a force to a piston-cylinder assembly and the pressure thus generated is applied to a larger piston-cylinder assembly.	±0.02 %.	Secondary
<i>Lever amplification machines</i>	A small deadweight machine with a set of levers which amplify the force	±0.02%.	Secondary
<i>Strain-gauged hydraulic machines</i>	The force applied to an instrument is reacted against by strain-gauged columns in the machine's framework.	±0.05%.	Secondary
<i>Reference force transducer machines</i>	A force transfer standard is placed in series with the instrument to be calibrated (typically in a materials testing machine).	±0.05%.	Secondary

7.3 Multi-axis and dynamic calibration

All the above techniques and standards have been developed for the calibration of systems to measure static forces acting along a single well-defined axis. Calibrations are also required for multi-axis situations and for systems which measure non-static (dynamic) forces.

Multi-axis calibration is similar to single axis calibration but done once for each axis. The calibration of multi-component force sensors is more demanding on the equipment, although the principles remain the same. Measurement of *cross talk* requires some new considerations. Cross talk is the effect of a calibration force applied along one axis on a different component, for example an output on the x-axis transducer caused by a y-component force. To measure cross talk of 0.1% with a maximum uncertainty of 0.01% requires a force alignment to a perfectly perpendicular theoretical angle of less than 20', illustrating the need for special test machines.

At the time of writing *dynamic force calibration* is not yet an established procedure [36]. The statically derived force transducer sensitivities are assumed to be applicable for dynamic force measurements. The dynamic behaviour (natural frequency) of load washers or dynamometers depends very much on the stiffness and weights involved of the structure where the sensor is mounted. Some sensor manufacturers therefore do not state this value.

7.4 Options

There are three main calibration options available for establishing the uncertainty of the force measurement system. The first is to leave the force transducer in its permanently installed position and use a transfer standard to carry out the calibrations. The second is to calibrate the force transducer prior to installation and remove as required for further calibrations. The final option is to calibrate the force transducer prior to its permanent installation in the force measurement system and then not to recalibrate during the life of the installation.

7.4.1 Permanently installed transducer with transfer standard

The preferred option for a system which requires a low level of uncertainty is to permanently install the force transducer, then use a transfer standard to provide regular calibrations. Prior to installation the permanent force transducer should be calibrated over its full operational range, replicating where possible the anticipated operational conditions including the range, direction, rate of change and duration of applied force, as well as temperature and simulation of a typical working cycle. This initial calibration, which may have been carried out by the manufacturer prior to delivery, is used to determine creep, non-return to zero, hysteresis and non-linearity.

At suitable intervals during the life of the system, a transfer standard is installed in the rig in series with the permanent device and the outputs are compared over a range of applied forces. These calibrations ensure that the uncertainty level is maintained, and also assist in identifying any changes or problems to the installation or transducer. The use of automated calibrations may be appropriate when trying to meet low limits of uncertainty and/or tight calibration time-scales. Automated calibration may more accurately reflect the operational conditions of the force measurement transducer and hence can reduce the system uncertainty.

7.4.2 Removable force transducer

If the force transducer can be removed from the installation, then in addition to the initial calibration the transducer may be removed periodically for re-calibration against a standard. This method gives an accurate calibration to the transducer, but may not take into account losses in the installation such as friction, lever ratios and so on. The instrumentation may be calibrated with the transducer or separately against another standard.

7.4.3 Permanently installed force transducer without transfer standard

A permanently installed force transducer without periodic calibration may be considered when both removal and in-situ calibration are impractical. The initial calibration should establish a level of uncertainty well within the system requirements to accommodate drift and deterioration in the force transducer during its operational life. Some confidence in the ongoing operational uncertainty may be achieved by periodically performing a shunt calibration and checking one or more well-defined operating points including zero applied force. In this case the user may not claim any traceability, even if the initial calibration was to a traceable standard.

7.5 Calibration procedures

7.5.1 Specifying the calibration

When planning the calibration of a force measurement system, the user needs to consider the following questions:

When to calibrate?

Different transducers operated under different conditions and with different uncertainty specifications will need re-calibrating at different intervals. A good starting point for deciding on *calibration interval* will be the manufacturer's literature for the device, particularly the specification for long-term stability. If after several calibrations it is apparent that the interval is too long (the calibration changes significantly each time) or too short (there is no appreciable change in calibration) then the period may be adjusted accordingly [13].

Whether to undertake the operation 'in-house' or subcontracted?

With suitable expertise, calibrations can be carried out successfully by the user without sending instruments to an outside laboratory. However, setting up an in-house **calibration facility** may require considerable investment in equipment and training. It is often better to have the work done by an expert laboratory, and perhaps one which holds a recognised measurement accreditation.

Calibrate in-situ or in a laboratory?

The ideal environment for a calibration of an instrument is usually considered to be a laboratory, where controlled and stable reference conditions can be provided. However, there are often good reasons for performing **in situ calibration** such as convenience, cost, to avoid disturbing the instrument or to calibrate it under the exact conditions of use.

Calibrate the whole system or just the transducer?

Normally it is best to calibrate the entire measurement chain from transducer to indicator using the same cables, instruments and power supplies. Sometimes this is impractical in which case the transducer and instrumentation should be calibrated separately to traceable standards.

Whether to request adjustment?

Calibration is sometimes taken to mean "adjustment of an instrument to read correctly". This is not true. Calibration and **adjustment** are quite separate concepts, and the two should not be confused. Thus, when arranging for the calibration of a force measuring system, it is important to establish clearly whether or not the system is to be adjusted as well as calibrated. If so, it should be specified whether calibration information is required only after adjustment, or whether results are also required for the initial or "as found" condition. Such "as found" information may be vital for traceability of the process within which the force measurement is made.

What is the required uncertainty level?

Both in the calibration and use of a force measurement system, the level of uncertainty needs to be considered. Some types of uncertainty can be quantified in terms of statistical techniques, such as standard deviation or spread, and these (often related to random effects) are known as **Type A components**. Uncertainties derived by any other method are known as **Type B components**, including systematic effects such as "engineering judgement". The **total** or **combined uncertainty** for a measurement is the combination of all the sources of uncertainty for that particular measurement. It is usual to combine the individual uncertainties using the "root-sum-squares" method (commonly known as u_{95} when given at a 95% confidence level) to obtain a total uncertainty. Thus:

$$\text{total uncertainty} = \pm[(u_1)^2 + (u_2)^2 + \dots + (u_n)^2]^{0.5}$$

where u_1, \dots, u_n are the individual uncertainty sources, all expressed at the same level of confidence and in the same non-dimensional units. While uncertainties exist at all times in the use of a force measurement system, often the only time they are specifically referred to is during the process of calibration.

The level of uncertainty required for the calibration of a force measurement system can only be determined by the user. The needs depend on the application and may be defined by the process (as in process control), by regulation (such as health and safety) or by standards in the particular industry. Calibration needs to be sufficient to meet these needs, but it would be wasteful to calibrate to too high a standard. If the force measurement requirement is $\pm 5\%$ of force applied then it would be a costly and pointless exercise to calibrate the device in a deadweight machine when a materials testing machine would do. As a guide, the uncertainty of measurement of the calibration machine should be 3 times better than the accuracy required from the

system to be calibrated. For example, if the uncertainty requirement on the transducer is $\pm 3\%$ then the calibration force uncertainty should be less than $\pm 1\%$.

What is the direction of force and the operating range of force?

The selection of the range of measurement should be carefully considered. A device is normally calibrated throughout its total range in tension or compression with more emphasis placed on the 20% to 100% of rated output. If the device under test is only used at 20% of rated force, it may not be necessary to calibrate up to 100%. In this case, limited calibrations are acceptable as long as the device is labelled as such.

What are the end loading conditions in the application?

The end-loading conditions in the calibration should match as closely as possible those in the application.

What is the temperature range for the application?

The transducer should be calibrated over the range of operating temperatures, and the uncertainty quoted should include the temperature effects.

7.5.2 Undertaking the calibration

An appraisal of the uncertainties of measurement attributed to the calibration equipment and method must be calculated and budgeted. This will include all aspects such as uncertainty of the load application device, environmental effects, loading effects etc. A percentage amount, either calculated or estimated, is attributed to each effect likely to be present.

Before taking any calibration readings the transducer should be pre-loaded up to its rated force and back to zero several times. This is to ensure that any mechanical or electrical connection, offsets or mismatches have been allowed to 'settle-in'.

Generally in a complete calibration cycle the force is applied from the lower range limit to the upper range limit. Then the force is reversed back down to zero. The range can be 100 %, 10 % and 1 % fso. The result is the calibration curve which is used to establish the calibration values of sensitivity, linearity and hysteresis.

CERTIFICATE OF CALIBRATION

ISSUED BY: _____ Serial No: _____
Date of issue: _____

Company Name: _____

Telephone no. _____ Fax no. _____

FOR: Customer name _____

YOUR REFERENCE: _____
OUR REFERENCE: _____

DESCRIPTION: A force measuring system of 90 kN maximum capacity for use in compression, comprising a washer type piezoelectric load cell, and its associated charge amplifier.

The unit is powered from 240 V a.c. mains.

IDENTIFICATION: Piezoelectric Washer
Charge Amplifier: _____

DATE OF CALIBRATION: _____

The uncertainties are for a confidence probability of not less than 95%.
This certificate is issued in accordance with the requirements of the United Kingdom Accreditation Service as specified to the NAMES Accreditation Standard and NAMES Requirements. It provides traceability of measurement to recognized national standards, and to the units of measurement realized at the National Physical Laboratory or other recognized national standards laboratories. This certificate may not be reproduced other than in full, storage with the prior written approval of the issuing laboratory.

Figure 16. Front page of a calibration certificate

Repeatability is probably the most important factor governing the suitability of a force transducer for its desired function. Depending on the uncertainty of measurement required it is advisable to calibrate the device at the same force a minimum of 2 (preferably 3) times. Following the assessment for repeatability, it is advisable to check the device's short-term reproducibility. The most common simple method is to remove and replace the transducer in the calibration machine before carrying out a further calibration run.

When taking measurements, the applied force should always be approached from the same direction, and allowed to stabilise before a reading is taken. Also it is important that zero force is a well-defined mechanical point at the same level and direction, taking account of backlash etc. Should any measurement point be overshoot in the sequence, then the applied force should be reversed beyond the required level and the force approached from the correct direction again.

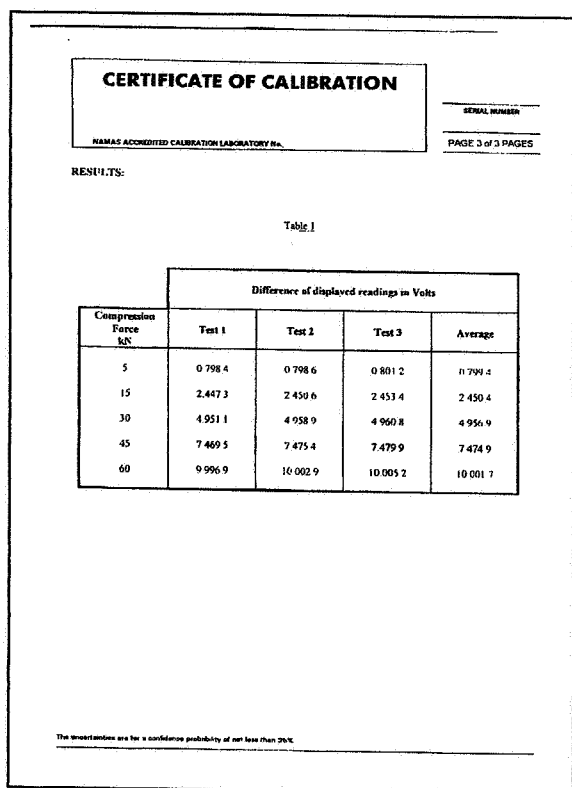

Figure 17. An example calibration certificate

7.5.3 Analysis of the calibration data

Analysis of the calibration data will often be carried out by the calibration laboratory and a *calibration certificate* supplied to the user when the transducer is returned. An example of a calibration certificate is given in Figure 16 and Figure 17. The user would be well advised to consider some of the following points regarding the data and the use he will make of it.

Check uniformity of results and range of errors

Confidence levels and uncertainties can be calculated from the numbers in the table, following the methods given in reference [31], but many users will simply wish to check that the range of errors (particularly the worst case) is well within their process needs.

Check for anomalies and bias.

A simple review of the figures in the table will help to discover any regular bias or systematic errors.

Check that linearity is within process needs.

The calibration data may be expressed graphically as a *calibration curve*. Normally on devices that require uncertainty of measurement of $\pm 0.5\%$ or better the force between calibration points is assumed to be linear (i.e. a straight line between points). Otherwise a polynomial equation can be fitted to the calibration data.

Any calibration corrections identified on a certificate of calibration should be applied to measured values obtained using that instrument. If the calibration corrections cannot be applied, the quoted uncertainty in the results should include an allowance for this.

Look at the history of the device – are there any unexpected changes?

The *calibration history* of a device (the ‘as found’ and ‘after adjustment’ curve at each calibration) may be important elements in the traceability of the machine or process in which the transducer is used. The history should be carefully kept following quality assurance rules.

8 QUALITY ASSURANCE OF FORCE MEASUREMENTS

8.1 Measurement accreditation

Many organisations are granted a recognised certification or accreditation for their activities. Certification may cover an organisation's overall quality management system, eg. BS EN 9000 series [12]. However, a generalised quality certification does not address the details of specialised technical practices. *Accreditation*, on the other hand, means that certain aspects of their business have been independently assessed, and that they comply with given criteria of competence and quality.

The United Kingdom Accreditation Service (*UKAS*) undertakes the National Accreditation of Measurement and Sampling (*NAMAS*). *NAMAS* accreditation of a calibration or testing laboratory provides assurance that measurements are carried out to the highest standards of technical competence, traceable to recognised national or international standards, using agreed methods, and with realistic statements of uncertainty. The *NAMAS* regulations are based on international standards on the operation and accreditation of laboratories, such as EN 45000 [14] and ISO Guide 25 [23]. *NAMAS* certificates are widely recognised and accepted throughout the UK and also world-wide.

Counterparts of *NAMAS* exist in many other countries, and in many cases are recognised as being exactly equivalent. Formal agreements provide for the mutual recognition of certificates from different national accreditation schemes. The European co-operation for Accreditation (*EA*) is the body which is the focus for multilateral recognition among national measurement accreditation schemes in Europe.

8.2 Competence in force measurement

What is assured when a laboratory or its personnel are said to be have technical *competence in force measurement*? Well, reading this Guide does not in itself lead to competence! Practical skill and experience are also required. However, it can safely be said that if personnel are to be considered to be competent in force measurement, they should be familiar with much - if not all - of the information in the preceding chapters, for those kinds of instrument they use.

This document is a guideline, not a prescriptive specification or accreditation standard. However, it does summarise most of the widely accepted best practices in force measurement. Therefore, it is reasonable to expect that any force laboratory that has passed a *NAMAS* or equivalent assessment by an expert in the field will generally follow the practices described in this Guide. This does not mean, of course, that a competent laboratory need necessarily undertake all the types of measurement described here. Nor does it mean that they need use this document in order to be applying the good practices described here.

Broadly speaking, therefore, a competent laboratory (whether accredited or not) could be expected to implement most of the recommended practices in Sections 6 and 7 for those types of force measurement they undertake. Laboratory personnel competent in force measurement could be expected to be familiar with the instrument characteristics listed in Section 4 for any instrument types they deal with.

9 WORKED EXAMPLES

9.1 Example: Measurement of web tension

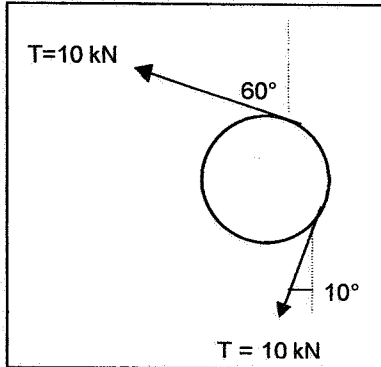

Figure 18. Forces on the roller

From a manufacturer's enquiry sheet we find that a customer wishes to measure a normalised web tension of 5 kN per metre width in a continuous production process on a 2 metre wide roller. The roller has a mass of 750 kg, the material of the web is wrapped 110° around the roller, and the exit angle of the web is 10° from vertical. The maximum tension T , is thus given by:

$$T = 2 \text{ m} \times 5 \text{ kN/m} = 10 \text{ kN.}$$

The arrangement is shown in Figure 18, and the resultant web forces can be calculated by means of a vector diagram as shown in Figure 19.

If T is the web tension then R is the resultant force acting on the roller due to the web tension. R may itself be resolved into vertical and horizontal force components R_1 and R_2 as shown in the figure. The force due to gravity acting on the mass of the roller is shown as W .

There are two possible ways of measuring the tension, given below as solution 1 and solution 2.

9.1.1 Solution 1

One possible solution is to install force transducers that go into the bearing assembly that can be orientated in rotation so that

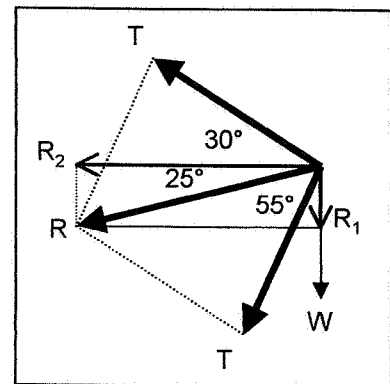

Figure 19. Vector diagram of forces

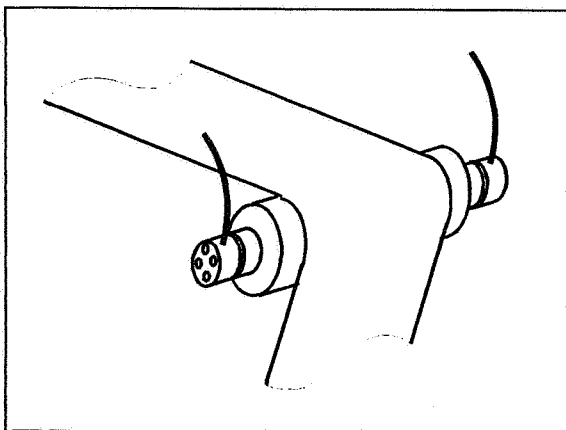

Figure 20. Alignable force transducers

their measuring axis is aligned with the resultant force R and thus only measure that component. Figure 20 shows the roller mounted on alignable force transducers.

$$\begin{aligned} \text{The resultant force, } R &= 2 T \cos (110^\circ/2) \\ &= 2 \times 10 \cos (55^\circ) \\ &= 20 \times 0.5736 \\ &= 11.47 \text{ kN} \end{aligned}$$

$$\begin{aligned} \text{The force per side, (assuming one support point} & \\ \text{either side)} &= 11.47 / 2 \\ &= 5.74 \text{ kN} \end{aligned}$$

$$\begin{aligned} \text{Mass suspended per side} &= 750 \text{ kg} / 2 \\ &= 375 \text{ kg} \end{aligned}$$

$$\begin{aligned} \text{Force acting due to mass of roll (W)} &= 375 \times 9.81 \text{ kg m s}^{-2} \\ &= 3.68 \text{ kN} \end{aligned}$$

From the calculations above it can be seen that the chosen force transducer must be capable of measuring a force of 5.74 kN along its principal axis and supporting and ignoring a side force of 3.68 kN at 65 degrees to that axis.

Let us assume that the nearest capacity force transducer to do this is rated at 10 kN, remembering to always go to the next capacity up and to consider start-up forces which may be greater than average. This will be, for example, connected to a force transducer signal conditioner (usually a combined power supply and amplifier) with ± 10 volts output and a digital display.

Then the system scaling would be: -

A force of 5.74 kN on a 10 kN capacity force transducer is scaled as 0-10 volts output and reads 0-5.00 kN m^{-1} on the digital display.

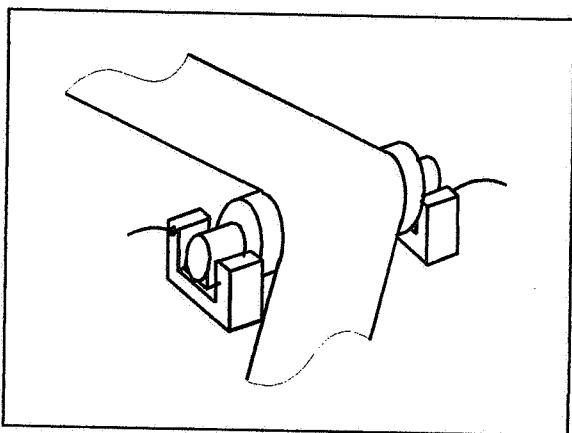

Figure 21. Force transducers in solution 2

$$\begin{aligned} \text{Force per side} &= 4.85 \text{ kN} / 2 \\ &= 2.43 \text{ kN} \end{aligned}$$

The horizontal component of force due to the web tension is R_2 .

$$\begin{aligned} R_2 &= R \cos (90^\circ - 65^\circ) \\ &= 11.472 \text{ kN} \times 0.9063 \\ &= 10.4 \text{ kN} \end{aligned}$$

$$\begin{aligned} \text{Force per side} &= 10.4 \text{ kN} / 2 \\ &= 5.2 \text{ kN} \end{aligned}$$

If the force transducers chosen only measure in the vertical direction then total force to be measured in the vertical direction is $2.43 \text{ kN} + 3.68 \text{ kN} = 6.11 \text{ kN}$.

The chosen force transducer must be capable of measuring a force of 6.11 kN along its principal axis and capable of withstanding 5.2 kN in its side axis. That is it must withstand and ignore 85% side force compared with the force along its principal axis!

9.1.2 Solution 2

A second solution is to install force transducers that go under the roller bearings and measure the vertical component of the tension R_1 in addition to the force acting on the roll due to gravity, as shown in Figure 21.

The vertical component of Force due to the Web Tension is

$$\begin{aligned} R_1 &= R \cos (55^\circ + 10^\circ) \\ &= 11.472 \text{ kN} \times 0.4226 \\ &= 4.85 \text{ kN} \end{aligned}$$

Supposing the next highest capacity force transducer above 6.11 kN is 10 kN. This will be, for example, connected to a force transducer signal conditioner (usually a combined power supply and amplifier) with 10 volts output and a digital display.

Then the system scaling would be:

a force of 2.43 kN on a 10 kN capacity force transducer on top of a tare force offset of 3.68 kN is scaled as 0-10 volts output and reads 0-5.00 kN m⁻¹ on the digital display;

or,

a force change of 3.68 to 6.11 kN on a 10 kN capacity force transducer, is scaled as 0-10 Volts output and reads 0-5.00 kN m⁻¹ on the digital display.

9.2 Example: Force measurement on a mechanically-driven power press

Press load monitoring is a technique now generally used in industry where the press and tool damage caused by excessive force is minimised by detecting the force level using sensors mounted on the press or in the tool. If the maximum value of the force exceeds a pre-set value the monitor signals the press to stop. Monitors can also be supplied to check for underload such that if the peak force does not reach a specified value then press operation will be stopped.

Curve monitoring systems check the complete force curve and if any point on the curve deviates either from its correct force or crank angle position then press operation will be stopped or an alarm activated to indicate a quality deviation.

9.2.1 Machine force monitors

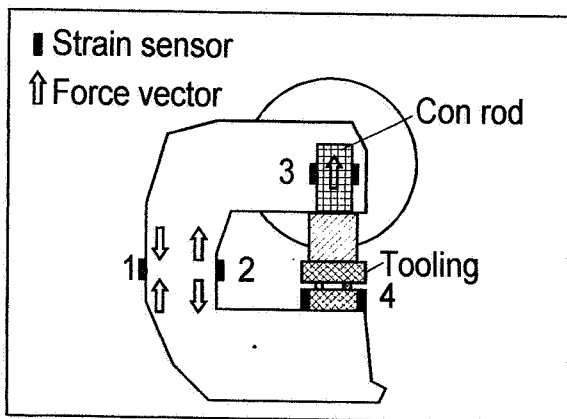

Force monitors operate by using strain sensors mounted in various key locations to measure deflections that are proportional to the applied force. The general rule is that sensors should be mounted as close to the tool as is practical. This becomes more particularly important with curve monitoring systems. Figure 22 shows typical locations, namely:

- Frame(1),
- Tiebeam (2),
- Connecting rods (3),
- Tool/die (4).

Figure 22. Sensor locations on a C-frame press

9.2.2 In-tool measurement of force

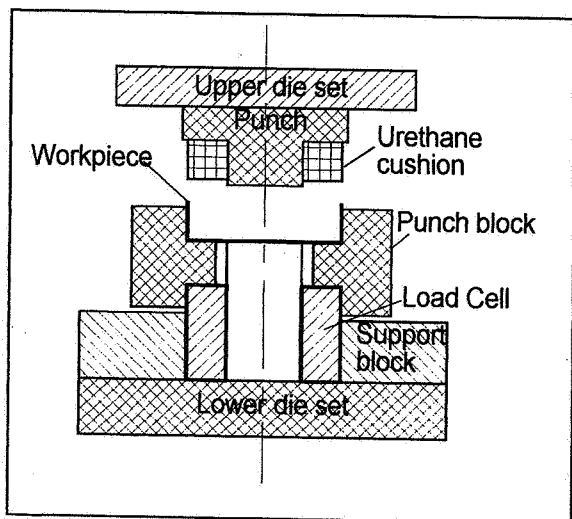

Figure 23. Blank and draw tool

A typical application of in-tool force measurement is shown in Figure 23 for a blank and draw tool in a power press. The force transducer mounted in the die checks for peak force and also a number of material properties and other features. Examples of measured curves are given in Figure 24 that illustrate the effect of material hardness changes. Tool wear and material thickness variations can also be monitored.

Note in Figure 23 the gap between the punch block and the support block. This gap exists so that all the force passes through the force transducer. If the punch block contacts the support block at any time then a force shunt is created and a measurement error introduced.

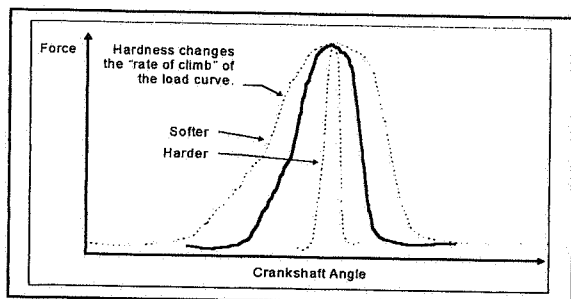

Figure 24. Load curve examples

9.3 Example: Spring force test on a personal computer mouse

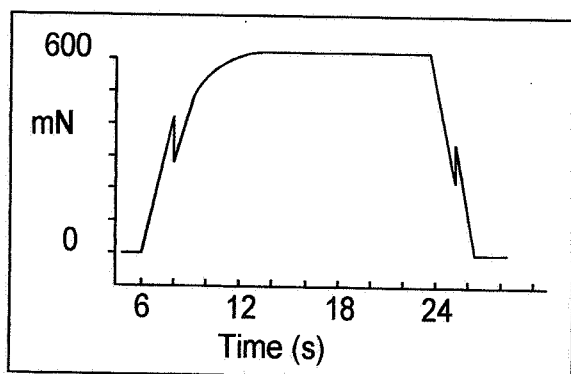

Figure 25. Response curve from mouse 'click' testing

A company that made computer mice needed to check the spring force of the buttons to ensure the correct 'feel'. A small test station was designed to ensure that the force at the click point was in the range of 450 mN to 700 mN. This test rig incorporated two piezoelectric transducers. The output was fed to amplifiers with a built-in monitoring facility that detected springs that were not within the specified range. This system allowed the user to accumulate data for automatic statistical quality control of the process. Figure 25 shows an example curve of results with the 'down-click' at about 8 seconds and the 'up-click' at about 25 seconds.

9.4 Example: Force measurement in bio-mechanics

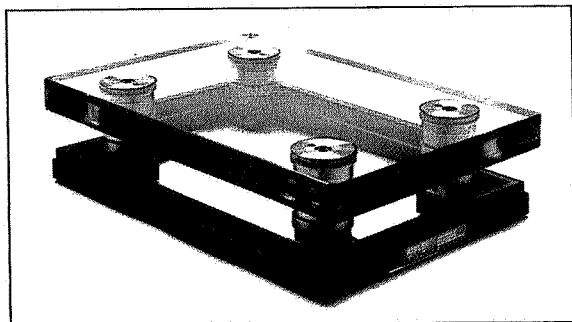

Figure 26. A transparent multi-component force plate

An application of multi-component force transducers is the measurement of locomotion forces using a *force dynamometer* or *force plate*. These devices are made by mounting a plate on four suitably-rated multi-component force transducers, as shown in Figure 26. The outputs from each transducer can then be added in each axis to give total force in that direction, or the difference in forces on each support point can be used to calculate the centre of force action in any axis.

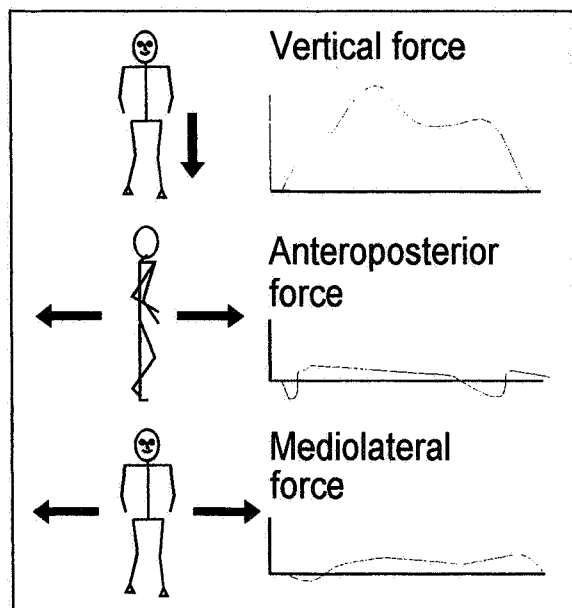

Figure 27. Example of human gait analysis

The calculation software and display for such a system would normally be provided as a complete unit by the manufacturer. The user would need to specify the magnitude of forces along each axis, the maximum rate of change of those forces and size of plate required.

Force plates are extensively used in clinical measurement of patients with gait problems such as patients with cerebral palsy or those with lower limb amputation to optimise the artificial limbs provided or to correct gait problems (see the example in Figure 27).

These devices are also extensively used in sports science to gain an accurate measurement of the ground reaction forces so that performance can be optimised. This is particularly important for international competitors where even a small improvement can be critical.

Applications for force plates also include studies to optimise the design of sports shoes; for analysing the movement of various animals, particularly racehorses; to determine the safety of floor coverings (liability to cause slip). Industrial applications include the measurement of the thrust of rockets and torque measurements on motors attached to the surface of the plate.

10 FURTHER INFORMATION SOURCES

10.1 Bibliography

10.1.1 Standards

- [1] BS 1610 British Standard - Materials testing machines and force verification equipment.
- [2] BS 1610: Part 1: 1992 British Standard - Specification for the grading of the forces applied by materials testing machines when used in the compression mode.
- [3] BS 1610: Part 2: 1985 British Standard - Specification for the grading of equipment used for the verification of the forces applied by materials testing machines. Superseded by BS EN 10002-3.
- [4] BS 1610: Part 3: 1990 British Standard - Specification for the grading of the forces applied by deadweight and lever creep testing machines.
- [5] BS 5233:1986 British Standard - Glossary of terms used in metrology (incorporating BS 2643).
- [6] BS 5844:1980 (1987) (ISO 5168 - 1978) British Standard - Methods of Measurement of Fluid Flow: estimation of uncertainty of a flow-rate measurement.
- [7] BS 6739: 1986 British Standard - Code of practice for instrumentation in process control systems: installation, design and use.
- [8] BS EN 10002 British Standard on tensile testing of metallic materials.
- [9] BS EN 10002-1: 1992 British Standard - Method of test (at ambient temperature).
- [10] BS EN 10002-2: 1992 British Standard - Verification of the force measuring system of the tensile testing machine.
- [11] BS EN 10002-3: 1995 British Standard - Calibration of force proving instruments used for the verification of uni-axial testing machines.
- [12] BS EN ISO 9000: 1994 British Standard - Quality systems - model for quality assurance in design, development, production, installation and servicing.
- [13] BS EN 30012-1: 1994 British Standard - Metrological confirmation system for measuring equipment.
- [14] BS EN 45000 (BS 7501: 1989) British Standard - General criteria for the operation of testing laboratories.
- [15] BS EN 60529 : 1992 British Standard - Specification for degrees of protection provided by enclosures (IP code).
- [16] BSI PD6461: Part 3: 1995 British Standard - Guide to the expression of uncertainty in measurement. ISBN 0-580-23482-7.
- [17] ISO Guide to the expression of uncertainty in measurement. International Organisation for Standardisation, Geneva. ISBN 92-67-10188-9.
- [18] ISO International vocabulary of basic and general terms in metrology. Second Edition, 1993. International Organisation for Standardisation, Geneva. ISBN 92-67-01075-1.
- [19] ISO 10012-1 (BS 5781: Part , 1992) Quality assurance requirements for measuring equipment.
- [20] ISO 376: 1987 (E) International Standard on Metallic materials - Calibration of force-proving instruments used for the verification of uni-axial testing machines. International Organisation for Standardisation, Geneva.
- [21] ISO 7500 International Standard on metallic materials - verification of static uni-axial testing machines. International Organisation for Standardisation, Geneva.
- [22] ISO 7500/1-1986 (E) Tensile testing machines. International Organisation for Standardisation, Geneva.
- [23] ISO Guide 25 1990 General requirements for the competence of calibration and testing laboratories. International Organisation for Standardisation, Geneva.
- [24] SI: The International System of Units (Translation of international bureau of weights and measures publication *Le système international d'unités*) edited by R.J. Bell, 1993 (Sixth edition).

10.1.2 Guidance Documents

- [25] A guide to the Measurement of Humidity. Institute of Measurement and Control, London, 1996. ISBN 0 904457 24 9.
- [26] Guide to the Measurement of Mass and Weight. Institute of Measurement and Control, London, 1998. ISBN 0 904457 27 3.
- [27] Guide to the Measurement of Pressure and Vacuum. Institute of Measurement and Control, London, 1998. ISBN 0 904457 29 X.
- [28] WGC0496. A code of practice for the calibration of industrial process weighing systems. Institute of Measurement and Control, London, 1996. ISBN 0 904457 23 0.
- [29] WGL9301. A procedure for calibration and testing of strain gauge load cells used for industrial process and force measurements. Institute of Measurement and Control, London, 1993.
- [30] NAMAS document NIS0404. Accreditation for the calibration of force measuring equipment and verification of materials testing machines. August 1995.
- [31] NAMAS document M3003. The Expression of Uncertainty and Confidence. Edition 1, 1997.
- [32] NAMAS leaflet MI. Introducing NAMAS.
- [33] NAMAS leaflet P3. What's so special about a NAMAS laboratory report or certificate?

10.1.3 Books and Theses

- [34] An Introduction to Measurements using Strain Gages. Hoffmann, K. Hottinger Baldwin Messtechnik GmbH, 1989
- [35] Uncertainty, Calibration and Probability. 2nd edition 1991. Adam Hilger, Bristol.
- [36] Development of a dynamic force measurement standard. Dixon, M.J. Brunel University, May 1989.
- [37] Intrinsically Safe Instrumentation - A Guide, 3rd edition. Garside R. Hexagon Technology Ltd., 2 West End, Weston Turville, Aylesbury, Bucks. HP22 5TT. 1995
- [38] Material Science - p 499. Anderson, Leaver, Rawlings and Alexander. 1991
- [39] Piezoelectricity. Anon. Veritron, Southampton, 1969.
- [40] Statistics for technology. 3rd edition. Chatfield, C. Chapman and Hall, London, 1983.
- [41] Piezoelectric measuring instruments and their applications. Kail R. and Mahr W. Translated and published by Kistler Instruments AG Winterthur Switzerland. 1984.
- [42] Piezoelektrische Messtechnik. Tichy J., and Gautshi G. Springer-Verlag, Berlin - Heidelberg - New York. 1980
- [43] Theory and practise of force measurement. A. Bray, G. Barbato and R. Levi. Academic Press 1990.

10.2 Useful addresses

British Standards Institution (BSI), 389 Chiswick High Road, London W4 4AL

Institute of Measurement and Control (InstMC), 87 Gower Street, London WC1E 6AA

International Organisation for Standardisation (ISO), Case Postale 56, CH-1211 Genève 20, Switzerland

National Physical Laboratory (NPL), Queens Road, Teddington, Middlesex TW11 0LW

United Kingdom Accreditation Service (UKAS), Queens Road, Teddington, Middlesex TW11 0NA

11 INDEX

A

accreditation, 37
accuracy, 6
adjustment, 34
analogue output, 25
artefact, 6
axial alignment of force, 9
axle load, 23

B

bi-directional force transducer, 24
bus, 25

C

cable laying, 21
calculated value, 6
calibration, 6, 31
calibration certificate, 36
calibration curve, 36
calibration facility, 34
calibration history, 36
calibration interval, 33
capacitive load cells, 18
charge amplifier, 15
combined error, 7
combined uncertainty, 34
competence in force measurement, 37
component testing, 20
creep, 8
creep recovery, 8
cross talk, 32
cutting force and torque, 22

D

data collection, 26
deadweight machines, 32
derived unit, 4
device, 6
digital output, 25
documentary standard, 6
drilling force, 22
dynamic force, 9
dynamic force calibration, 32
dynamic overload, 28

E

EA (European co-operation for Accreditation), 37
elastic element, 11
electrical resistance strain gauges, 12
environment, 26
error of measurement, 7

F

fatigue life, 9
foil strain gauge, 12
force, 5
force balance, 19
force dynamometer, 25, 42
force measurement system, 6
force measuring pins, 16
force plate, 42
force proving instruments, 31
force shunts, 27
force standard machines, 31
force transducer, 6
force transfer standard, 31
frequency response, 9
fso, 7
full-scale output, 7

G

gas turbine thrust, 20
gauge factor, 13
gyroscopic load cells, 19

H

hydraulic amplification machines, 32
hydraulic load cell, 17
hysteresis, 7

I

indicated value, 6
influence quantities, 8
in-situ calibration, 34
installation, 27
instrumentation, 6
interference-optical load cell, 18
international standard, 31
interpolation classification, 31
intrinsically safe operating system, 26
IP code, 26

L

level of confidence, 6
lever amplification machines, 32
linear variable differential transducer (LVDT), 18
load, 5
load cell, 6
loading column, 17
loading conditions, 8
loading surfaces, 8
long-term stability, 9

M

magneto-elastic force transducer, 19
mass, 4
material measure, 6
materials testing machines, 20, 31
metal rolling, 21
metrology, 3
mooring forces, 22
multi-axis calibration, 32
multi-component piezoelectric force transducers, 16
mV/V, 14

N

NAMAS, 37
national standard, 31
natural frequency, 8
newton, 5
non-linearity, 7

O

optical strain gauge, 18
output, 6
overload, 5

P

piezoelectric crystal, 15
pipe-laying tension, 21
plastic deformation, 19
pneumatic load cell, 17
pressing sheet metal, 22
primary standards, 31
principal axis, 5
process weighing, 23
proving ring, 17

Q

quartz force transducer, 15

R

rated capacity, 7
rated output, 7
reaction, 5
reference force transducer machines, 32
repeatability, 7
reproducibility, 8
response curve, 7

S

safety requirements, 26
scientific notation, 4
secondary standards, 31
semiconductor strain gauges, 13
sensitivity, 7
shear pin force transducers, 21
shunt calibration, 28
shunt resistor, 14
SI system of units, 4
side forces, 28
six-wire connection technique, 14
slew, 26
span, 7
specific forces classification, 31
specification, 6
standard, 6
strain-gauged hydraulic machines, 32
surface-wave resonator, 18

T

temperature coefficient, 8
tension leg platforms, 22
thin-film strain gauges, 13
thrust measurement. *See* gas turbine thrust
torque measurement, 20
total uncertainty, 34
traceability, 31
transducer, 6
transfer standard. *See* force transfer standard
tuning-fork load cell, 18

U

UKAS, 37
uncertainty, 6
 Type A components, 34
 Type B components, 34
uni-directional force transducer, 24
unit, 4

V

vibrating-wire transducer, 18

W

warm up, 27
web tension, 21
wheatstone bridge configuration, 13
wire strain gauge, 13